

Static Pressure Probe

Model A-520



- **Unique dual orifice design to eliminate air flow error**
- **Gasketed flange for ease of installation**
- **1/4" brass hose barb connection for transducer/switch**
- **Available in 4" and 8" probe lengths**
- **6061T-6 aluminum alloy**
- **Gasketed mounting flange, brass connector and mounting holes guarantee quick and easy installation**

The A-520 Static Pressure Probe is designed to pick up static pressure in a duct, plenum, air handler or other HVAC equipment. The Probe has two orifices vertically opposite each other to cancel out any air flow induced errors. If a bent tube with a single orifice at the end is used to pick up static pressure in a duct, the air flowing across the probe may cause a small low pressure within the probe. This low pressure acts against the duct static pressure and hence induces an error which is exponentially proportional to the air flow. As the air flow increases, this error will increase also and as the flow decreases, the error decreases in an exponential relationship.

The engineers at MAMAC Systems resolved this problem with a unique design which incorporates two orifices diametrically opposing each other in a vertical plane. When the air flows across an orifice, it creates a suction towards that orifice. Similarly, when the same air flows across the other orifice, it creates an opposing suction which cancels out the first pressure drop. Regardless of the velocity, the flow error is constantly cancelled out and the A-520 provides an accurate,

The A-520 Static Pressure Probe is available in 6061T-6 aluminum alloy or 304 stainless steel material. In this way, for standard HVAC applications, the aluminum probe can be used. However, in exhaust applications where corrosive gases are present, the 304 stainless steel is recommended. The A-520 is available in two probe length options: 1) 4" aluminum/stainless steel; 2) 8" aluminum/ stainless steel. The Probe is attached to a 2" O.D. flange with two conveniently located mounting holes for ease of attachment to the sheet metal. The flange also has a neoprene gasket to seal off the mounting holes. An industry standard 1/4" hose barb or 1/8" NPT female swivel brass fitting is provided for PVC/copper tubing connection. The A-520 is designed to substantially reduce the installation time required and to provide a convenient method to pick up static pressure in HVAC equipment.

Installation is completed by drilling a 1/4" hole in the sheet metal, inserting the Probe and securing the assembly by using the mounting flange as a template to mark and drill two holes for the self tapping sheet metal screws. A label is provided to correctly position the mounting holes during installation to insure that the two orifices are perpendicular to the air flow.



MAMAC SYSTEMS®
MONITOR • DECISION • CONTROL
7400 Flying Cloud Drive Minneapolis, MN 55344-3720 • USA
800/843-5116 • 612/835-1626 • Fax 612/829-5331
sales@mamacsys.com • www.mamacsys.com

Units 6&7 Baird House • Dudley Innovation Centre
Pensnett Estate • Kingswinford
West Midlands • DY6 8XZ • United Kingdom
Tel 01384-271113 • Fax 01384-271 114

1st Floor • Esanda House • 104 Frome Street
Adelaide • S. A. 5000 • Australia
Tel 08-232-4551 • Fax 08-232-4715

155 McIntosh Drive, Unit 5 • Markham
Ontario • L3R 0N6 • Canada
Tel 905-474-9215 • Fax 905-474-0876

5611 North Bridge Road
03-06 • Eng Cheong Tower
Singapore • 911901
Tel 65-3927273 • Fax 65-3927276

© Registered Trademark MAMAC SYSTEMS, Inc.

A-520

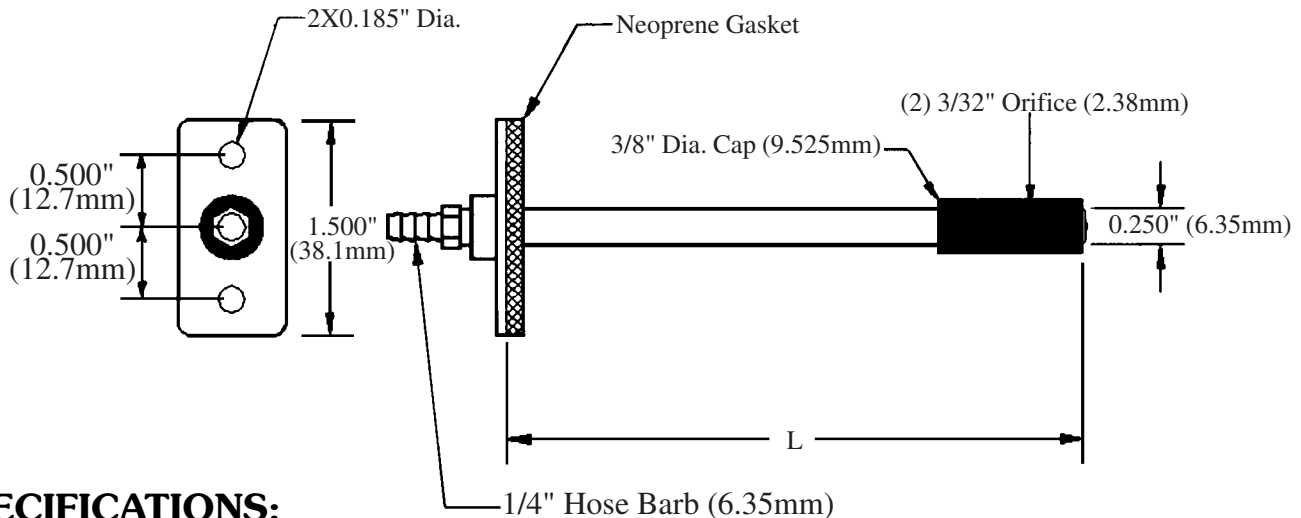

SPECIFICATIONS:

Material: 6061T-6 Aluminum Alloy or 304 Stainless Steel
Port Connections: 1/4" brass hose barb or 1/8" NPT female
Gasket Material: Neoprene
Maximum Pressure: 10 psig

Maximum Temperature: 250° C
Maximum Air Flow: Unlimited
Weight: 1.5 oz.

ORDERING INFORMATION:

| A-520 | PROBE LENGTH | MATERIAL | CONNECTOR |
|-------|--------------|--------------------|--------------------|
| | 1) 4" | A) Aluminum | 1) 1/4" hose barb |
| | 2) 8" | B) Stainless Steel | 2) 1/8" NPT female |

The MAMAC Systems warranty covers parts and labor for 2 years from date of shipment. MAMAC Systems reserves the right to change any specifications without notice to improve performance, reliability, or function of our products.

A Complete Line of Control Peripherals From a Single Source

MAMAC Systems is the only manufacturer offering more than fifty products to satisfy all temp, humidity, pressure, flow, light, speed or any other DDC controls application. MAMAC's complete line of control peripherals is available in over two thousand different configurations of supply voltage, output, range and enclosure type to make our products guaranteed compatible to all HVAC controls, industrial automation and COGEN systems worldwide.

Single source accountability, liberal 2 year warranty, worldwide service and technical support, competitive pricing, accumulated experience of more than 10,000 installations are some of the benefits offered by MAMAC Systems which are second to none in the HVAC DDC controls industry.



MAMAC SYSTEMS®
 MONITOR • DECISION • CONTROL

7400 Flying Cloud Drive Minneapolis, MN 55344-3720 • USA
 800/843-5116 • 612/835-1626 • Fax 612/829-5331
 sales@mamacsys.com • www.mamacsys.com

Units 6&7 Baird House • Dudley Innovation Centre
 Pensnett Estate • Kingswinford
 West Midlands • DY6 8XZ • United Kingdom
 Tel 01384-271113 • Fax 01384-271 114

1st Floor • Esanda House • 104 Frome Street
 Adelaide • S. A. 5000 • Australia
 Tel 08-232-4551 • Fax 08-232-4715

155 McIntosh Drive, Unit 5 • Markham
 Ontario • L3R 0N6 • Canada
 Tel 905-474-9215 • Fax 905-474-0876

5611 North Bridge Road
 03-06 • Eng Cheong Tower
 Singapore • 911901
 Tel 65-3927273 • Fax 65-3927276

® Registered Trademark MAMAC SYSTEMS, Inc.