

Minimum 18 in-lb torque

- For damper areas up to 6.8 sq-ft*



All Actuators have BDCM

CMB Series - At A Glance

		<i>CMB24-3 (p. 226)</i>	<i>CMB24-3-T (p. 226)</i>	<i>CMB120-3 (p. 228)</i>	<i>CMB24-SR-R (p. 230)</i>	<i>CMB24-SR-L (p. 230)</i>
Basic Product		•	•	•	•	•
Flexible Product						
Torque	18 in-lb [2 Nm]	•	•	•	•	•
Angle of Rotation	Endless	•	•	•		
	90 degrees				•	•
	330 degrees	•	•	•		
Power Supply	24 VAC/DC	•	•		•	•
Control Input	On/Off, Floating Point	•	•	•		
	2 to 10 VDC (4 to 20mA)				•	•
	Multi-Function Technology					
Feedback	None	•	•	•		
	2 to 10 VDC				•	•
	Variable (0 to 10 VDC)					
Running Time	35 seconds	•	•	•		
Wiring	Plenum Rated Cable	•	•		•	•
	Appliance Rated Cable			•		
	Terminal Strip		•			

Installation and Operation... (page 265).

*Based on 4 in-lb/ft² damper torque loading. Parallel blade. No edge seals.

A CLOSER LOOK...

- Brushless DC Motor for Added Accuracy and Controllability.
- Cut Labor Costs with Simple Direct Coupling.
- Self-Centers on 1/2" shafts with Universal Clamp.
- Check Damper Position with Clear Position Indicator.
- Don't Worry about Actuator Burn-Out; Belimo is Overload Proof throughout Rotation.
- Enjoy Added Flexibility with Easy Mechanical Stops to Adjust Angle of Rotation.
- Easy override with use of magnet located on position indicator.
- Mounts Directly on Clamp, Includes Conduit Connector.
- Standard 3ft Plenum Rated Cable Provided on Basic Models.



Bulk Packaging Offers Big Value for Large jobs, Stocking Orders.



The Belimo Difference

- **Customer Commitment.**
Extensive product range. Application assistance.
Same-day shipments. Free technical support. Five year warranty.
- **Low Installation and Life-Cycle Cost.**
Easy installation. Accuracy and repeatability.
Low power consumption. No maintenance.
- **Long Service Life.**
Components tested before assembly. Every product tested before shipment.
30+ years direct coupled actuator design.

K20901 - 01/09 - Subject to change. © Belimo Aircontrols (USA), Inc.

CMB24-3(-T)

On/Off, Floating Point Control, Non-Spring Return, Direct Coupled, 24V



Technical Data	CMB24-3(-T)
Power Supply	24 VAC ± 20% 50/60 Hz 24 VDC ± 20%
Power Consumption	1.0 W (0.2 W resting)
Transformer Sizing	1.5 VA (Class 2 power source)
Electrical Connection	3 ft, 18 GA appliance rated cable Protected NEMA 2 (IP54)
Overload Protection	electronic throughout rotation
Control	On/Off, Floating Point
Angle of Rotation	without end stop-limitless with end stop stop -315° fix 287.5° max. with 2 end stops
Torque	18 in-lb [2 Nm]
Direction of Rotation	by electrical installation
Position Indication	reflective visual indicator (snap-on), with magnet
Manual Override	disengage with magnet
Running Time	35 seconds, constant independent of load
Humidity	5 to 95% RH non condensing (EN 60730-1)
Ambient Temperature	-22°F to 122°F [-30°C to 50°C]
Storage Temperature	-40°F to 176°F [-40°C to 80°C]
Housing	NEMA 2, IP54, UL enclosure type 2
Housing Material	UL94-5VA
Agency Listings†	cULus acc. to UL 60730-1A/-2-14, CAN/CSA E60730-1:02, CE acc. to 2004/108/EEC and 2006/95/EC
Noise Level	<45dB(A)
Servicing	maintenance free
Quality Standard	ISO 9001
Weight	0.4 lbs [0.18 Kg]

CMB24-3-T	
Electrical connection	screw terminal (for 18 to 16 GA wire)
Form Fit	0.31" x 0.31" [8mm x 8mm]
Housing	NEMA 1/IP20
Weight	0.3 lbs [0.13 Kg]

†Rated Impulse Voltage 800V, Type of action 1, Control Pollution Degree 3 for 24-3-T Degree 2.

Torque min. 18 in-lb for control of damper surfaces up to 4.5 sq ft.

Application

Damper actuator for operating air control dampers in ventilation and air-conditioning systems for building services installations.

- For air control dampers up to approximately 4.5 sq ft
- Torque 2 Nm
- Nominal voltage AC/DC 24 V
- Control: Open-close or 3-point
- Running time 35 sec. @ 90°

Operation

Simple direct mounting on the damper spindle with a universal spindle clamp or form fit, supplied with an anti-rotation bracket to prevent the actuator from rotating.

Manual operation is possible with a magnet (the gearing latch remains disengaged as long as the magnet is in place).

Adjustable angle of rotation with mechanical end stops, that requires no tools to move or remove.

The actuator is overload-proof, requires no limit switches and automatically stops when the end stops is reached.

The CM24-3 actuator uses a brushless DC motor, which is controlled by an Application Specific Integrated Circuit (ASIC). The ASIC monitors and controls the actuator's rotation sensing (DRS) function to prevent damage to the actuator in a stall condition. Power consumption is reduced in holding mode.

Belimo's Halomo sensorless brushless DC motor spins by reversing the poles of stationary electromagnets housed inside rotational permanent magnets. The electromagnetic poles are switched by the an ASIC developed by Belimo. Unlike the conventional DC motor, there are no brushes to wear or commutators to foul. What is means is the brushless DC motor adds accuracy and reduces power consumption in a holding mode.

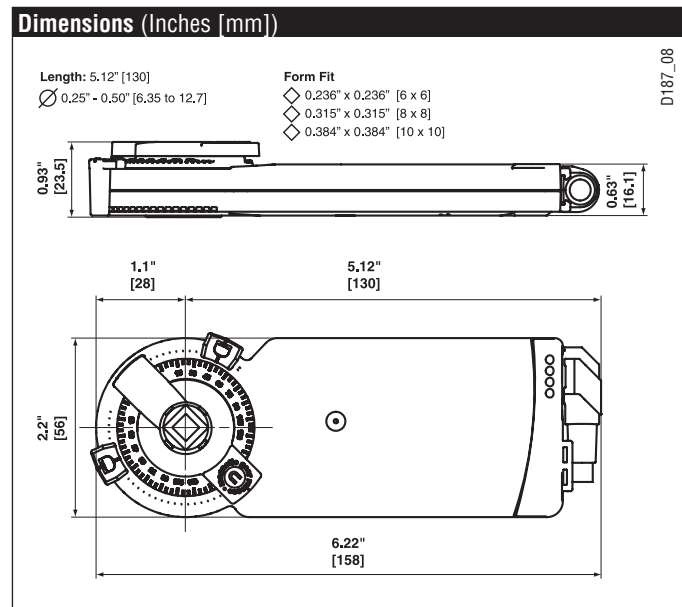

K20901 - 01/09 - Subject to change. © Belimo Aircontrols (USA), Inc.

Typical Specification

Floating point, on/off control damper actuators shall be electronic direct-coupled type, which require no crankarm and linkage and be capable of direct mounting to a shaft from 1/4" to 1/2". Actuators shall have brushless DC motor technology and be protected from overload at all angles of rotation. Actuators shall have manual override on the cover. If required, actuators will be provided with screw terminal strip for electrical connections (CMB24-3-T). Run time shall be constant and independent of torque. Actuators shall be cULus listed, have a 5-year warranty, and be manufactured under ISO 9001 International Quality Control Standards. Actuators shall be as manufactured by Belimo.

SAFETY NOTES

The damper actuator is not allowed to be used outside the specified field application, especially in aircraft or any other form of air transport.

Assembly must be carried out by trained personnel. Any legal regulations or regulations issued by authorities must be observed during assembly.

The device may only be opened at the manufacturer's site. It does not contain any parts that can be replaced or repaired by the user.

The cable must not be removed from the device.

When calculating the required torque, the specifications supplied by the damper manufactures (cross section, design, installation site), and the air flow conditions must be observed.

The device contains electrical and electronic components and is not allowed to be disposed of as household refuse. All locally valid regulations and requirements must be observed.

Wiring Diagram

INSTALLATION NOTES

- 1 Provide overload protection and disconnect as required.
- 2 **CAUTION Equipment damage!**
Actuators may be connected in parallel. Power consumption and input impedance must be observed.
- 3 Actuators may also be powered by 24 VDC.

APPLICATION NOTES

Meets cULus or UL and CSA Standard requirements without the need of an electrical ground connection.

WARNING Live Electrical Components!
During installation, testing, servicing and troubleshooting of this product, it may be necessary to work with live electrical components. Have a qualified licensed electrician or other individual who has been properly trained in handling live electrical components perform these tasks. Failure to follow all electrical safety precautions when exposed to live electrical components could result in death or serious injury.

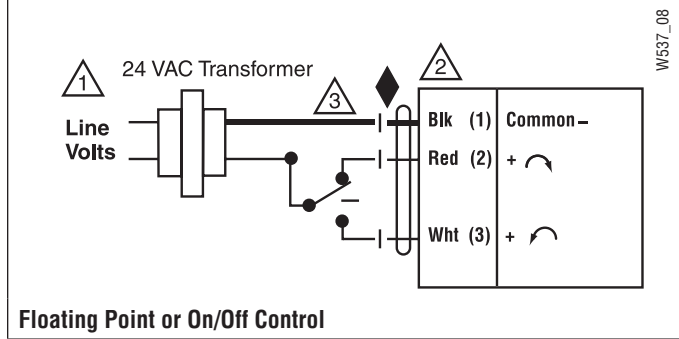
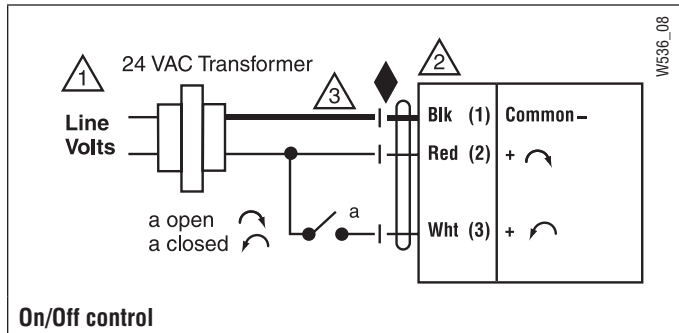



Technical Data		CMB120-3
Power Supply	nominal tolerance	100 to 240 VAC, 50/60 Hz 85 to 265 VAC, 50/60 Hz
Power Consumption		1.5 W (1.0 W)
Transformer Sizing		3.5 VA (Class 2 power source)
Electrical Connection		3 ft, 18 GA appliance rated cable Protected NEMA 2 (IP54)
Overload Protection		electronic throughout rotation
Control		On/Off, Floating Point
Angle of Rotation		without end stop-limitless with end stop stop -315° fix 287.5° max. with 2 end stops
Torque		18 in-lb [2 Nm]
Direction of Rotation		by electrical installation
Position Indication		reflective visual indicator (snap-on)
Manual Override		disengage with magnet
Running Time		35 seconds, constant independent of load
Humidity		5 to 95% RH non condensing (EN 60730-1)
Ambient Temperature		-22°F to 122°F [-30°C to 50°C]
Storage Temperature		-40°F to 176°F [-40°C to 80°C]
Housing		NEMA 2, IP54, UL enclosure type 2
Housing Material		UL94-5VA
Agency Listings†		cULus acc. to UL 60730-1A/-2-14, CAN/CSA E60730-1:02, CE acc. to 2004/108/EEC and 2006/95/EC
Noise Level		<45dB(A)
Servicing		maintenance free
Quality Standard		ISO 9001
Weight		0.4 lbs [0.18 Kg]

†Rated Impulse Voltage 2.5kV, Type of action 1.AA, Control Pollution Degree 3.

Torque min. 18 in-lb for control of damper surfaces up to 4.5 sq ft.

Application

Damper actuator for operating air control dampers in ventilation and air-conditioning systems for building services installations.

- For air control dampers up to approximately 4.5 sq ft
- Torque 2 Nm
- Nominal voltage AC/DC 100-240 V
- Control: Open-close or 3-point
- Running time 35 sec. @ 90°

Operation

Simple direct mounting on the damper spindle with a universal spindle clamp or form fit, supplied with an anti-rotation bracket to prevent the actuator from rotating.

Manual operation is possible with a magnet (the gearing latch remains disengaged as long as the magnet is in place).

Adjustable angle of rotation with mechanical end stops, that requires no tools to move or remove.

The actuator is overload-proof, requires no limit switches and automatically stops when the end stops is reached.

The CM24-3 actuator uses a brushless DC motor, which is controlled by an Application Specific Integrated Circuit (ASIC). The ASIC monitors and controls the actuator's rotation sensing (DRS) function to prevent damage to the actuator in a stall condition. Power consumption is reduced in holding mode.

Belimo's Halomo sensorless brushless DC motor spins by reversing the poles of stationary electromagnets housed inside rotational permanent magnets. The electromagnetic poles are switched by the an ASIC developed by Belimo. Unlike the conventional DC motor, there are no brushes to wear or commutators to foul. What is means is the brushless DC motor adds accuracy and reduces power consumption in a holding mode.

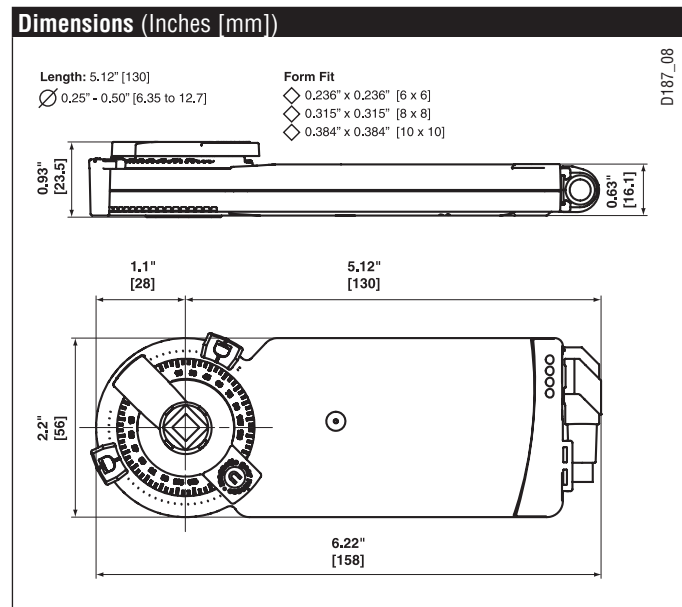

K20901 - 01/09 - Subject to change. © Belimo Aircontrols (USA), Inc.

Typical Specification

Floating point, on/off control damper actuators shall be electronic direct-coupled type, which require no crankarm and linkage and be capable of direct mounting to a shaft from 1/4" to 1/2". Actuators shall have brushless DC motor technology and be protected from overload at all angles of rotation. Actuators shall have manual override on the cover. Run time shall be constant and independent of torque. Actuators shall be cULus listed, have a 5-year warranty, and be manufactured under ISO 9001 International Quality Control Standards. Actuators shall be as manufactured by Belimo.

SAFETY NOTES

The damper actuator is not allowed to be used outside the specified field application, especially in aircraft or any other form of air transport.

Assembly must be carried out by trained personnel. Any legal regulations or regulations issued by authorities must be observed during assembly.

The device may only be opened at the manufacturer's site. It does not contain any parts that can be replaced or repaired by the user.

The cable must not be removed from the device.

When calculating the required torque, the specifications supplied by the damper manufactures (cross section, design, installation site), and the air flow conditions must be observed.

The device contains electrical and electronic components and is not allowed to be disposed of as household refuse. All locally valid regulations and requirements must be observed.

Wiring Diagram

INSTALLATION NOTES

- 1 Provide overload protection and disconnect as required.
- 2 **CAUTION Equipment damage!**
Actuators may be connected in parallel.
Power consumption and input impedance must be observed.

APPLICATION NOTES

Meets cULus or UL and CSA Standard requirements without the need of an electrical ground connection.

WARNING Live Electrical Components!

During installation, testing, servicing and troubleshooting of this product, it may be necessary to work with live electrical components. Have a qualified licensed electrician or other individual who has been properly trained in handling live electrical components perform these tasks. Failure to follow all electrical safety precautions when exposed to live electrical components could result in death or serious injury.

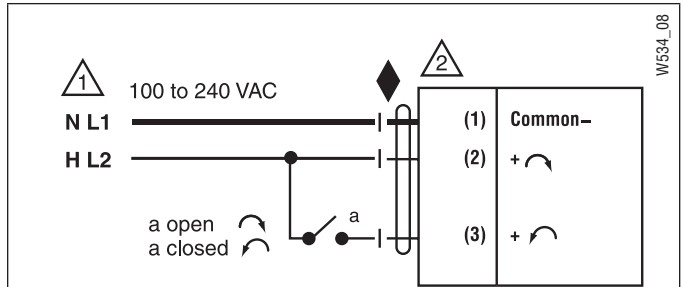

On/Off control

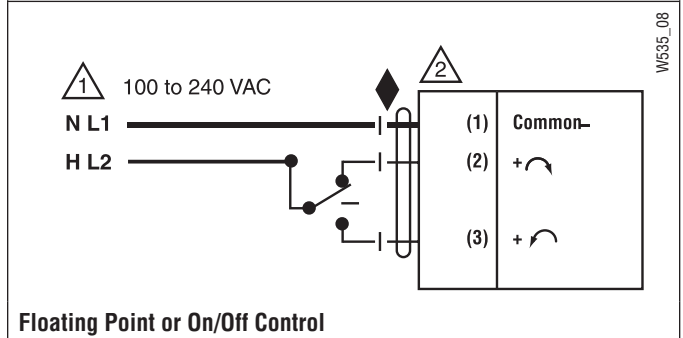

Floating Point or On/Off Control

K20901 - 01/09 - Subject to change. © Belimo Aircontrols (USA), Inc.

CMB24-SR-R(-L)

Proportional Control, Non-Spring Return, Direct Coupled, 24V for 2 to 10 VDC and 4 to 20 mA



Technical Data	CMB24-SR-R(-L)
Power Supply	24 VAC ± 20% 50/60 Hz 24 VDC ± 20%
Power Consumption	1.5 W (0.5 W resting)
Transformer Sizing	1.5 VA (Class 2 power source)
Electrical Connection	3 ft, 18 GA appliance rated cable Protected NEMA 2 (IP54)
Overload Protection	electronic throughout rotation
Operating Range Y	2 to 10 VDC, 4 to 20 mA
Angle of Rotation	without end stop-limitless with end stop stop -315° fix 287.5° max. with 2 end stops
Torque	18 in-lb [2 Nm]
Direction of Rotation	by electrical installation
Position Indication	reflective visual indicator (snap-on), with magnet
Manual Override	disengage with magnet
Running Time	35 seconds, constant independent of load
Humidity	5 to 95% RH non condensing (EN 60730-1)
Ambient Temperature	-22°F to 122°F [-30°C to 50°C]
Storage Temperature	-40°F to 176°F [-40°C to 80°C]
Housing	NEMA 2, IP54, UL enclosure type 2
Housing Material	UL94-5VA
Agency Listings	cULus acc. to UL 60730-1A/-2-14, CAN/CSA E60730-1:02, CE acc. to 2004/108/EEC and 2006/95/EC
Noise Level	<45dB(A)
Servicing	maintenance free
Quality Standard	ISO 9001
Weight	0.4 lbs [0.18 Kg] with form fit 0.3 lbs [0.13 Kg]

†Rated Impulse Voltage 800V, Type of action 1, Control Pollution Degree 3 for 24-3-T Degree 2.

Torque min. 18 in-lb for control of damper surfaces up to 4.5 sq ft.

Application

Damper actuator for operating air control dampers in ventilation and air-conditioning systems for building services installations.

- For air control dampers up to approximately 4.5 sq ft
- Torque 2 Nm
- Nominal voltage AC/DC 24 V
- Control: 2 to 10 VDC
- Running time 35 sec. @ 90°

Operation

Simple direct mounting on the damper spindle with a universal spindle clamp or form fit, supplied with an anti-rotation bracket to prevent the actuator from rotating.

Manual operation is possible with a magnet (the gearing latch remains disengaged as long as the magnet is in place).

Adjustable angle of rotation with mechanical end stops, that requires no tools to move or remove.

The actuator is overload-proof, requires no limit switches and automatically stops when the end stops is reached.

The CMB24-SR (-R or -L) actuator uses a brushless DC motor, which is controlled by an Application Specific Integrated Circuit (ASIC). The ASIC monitors and controls the actuator's rotation sensing (DRS) function to prevent damage to the actuator in a stall condition. Power consumption is reduced in holding mode.

Belimo's Halomo sensorless brushless DC motor spins by reversing the poles of stationary electromagnets housed inside rotational permanent magnets. The electromagnetic poles are switched by the an ASIC developed by Belimo. Unlike the conventional DC motor, there are no brushes to wear or commutators to foul. What is means is the brushless DC motor adds accuracy and reduces power consumption in a holding mode.

Dimensions (Inches [mm])

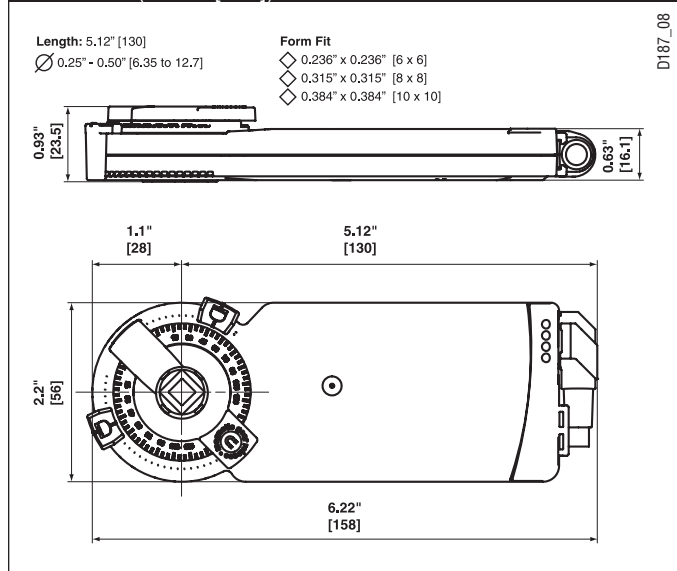

K20901 - 01/09 - Subject to change. © Belimo Aircontrols (USA), Inc.

Typical Specification

Proportional control damper actuators shall be electronic direct-coupled type, which require no crankarm and linkage and be capable of direct mounting to a shaft from 1/4" to 1/2". Actuators must provide proportional damper control in response to a 2 to 10 VDC or, with the addition of a 500 Ω resistor, a 4 to 20 mA control input from an electronic controller or positioner. Actuators shall have Brushless DC motor technology and be protected from overload at all angles of rotation. Run time shall be constant and independent of torque. A 2 to 10 VDC feedback signal shall be provided for position indication. Actuators shall be cULus listed, have a 5-year warranty, and be manufactured under ISO 9001 International Quality Control Standards. Actuators shall be as manufactured by Belimo.

SAFETY NOTES

The damper actuator is not allowed to be used outside the specified field application, especially in aircraft or any other form of air transport.

Assembly must be carried out by trained personnel. Any legal regulations or regulations issued by authorities must be observed during assembly.

The device may only be opened at the manufacturer's site. It does not contain any parts that can be replaced or repaired by the user.

The cable must not be removed from the device.

When calculating the required torque, the specifications supplied by the damper manufactures (cross section, design, installation site), and the air flow conditions must be observed.

The device contains electrical and electronic components and is not allowed to be disposed of as household refuse. All locally valid regulations and requirements must be observed.

Wiring Diagram

✂ INSTALLATION NOTES

- 1 Provide overload protection and disconnect as required.
- 2 **CAUTION Equipment damage!**
Actuators may be connected in parallel.
Power consumption and input impedance must be observed.
- 3 Actuators may also be powered by 24 VDC.
- 5 Only connect common to neg. (-) leg of control circuits.

📄 APPLICATION NOTES

- ◆ The ZG-R01 500 Ω resistor converts the 4 to 20 mA control signal to 2 to 10 VDC, up to 2 actuators may be connected in parallel.

⚠ WARNING Live Electrical Components!

During installation, testing, servicing and troubleshooting of this product, it may be necessary to work with live electrical components. Have a qualified licensed electrician or other individual who has been properly trained in handling live electrical components perform these tasks. Failure to follow all electrical safety precautions when exposed to live electrical components could result in death or serious injury.

