

## OpenAir™ GLB Series, 24 Vac, 88 lb-in, Non-spring Return, Direct-Coupled Electronic Damper Actuators

Product Number	Operating Voltage	Control		Cables			Built-in Control Options		
	24 Vac +20%, -15%	0 to 10 Vdc	3-position	Standard	Plenum	6-foot length	Potentiometer	Dual Auxiliary Switches	Slope and Offset
GLB131.1P	•		•		•				
GLB131.1Q	•		•			•			
GLB132.1P	•		•		•		•		
GLB136.1P	•		•		•			•	
GLB161.1P	•	•			•				
GLB161.1Q	•	•				•			
GLB163.1P	•	•			•				•
GLB164.1P	•	•			•			•	•
GLB166.1P	•	•			•			•	

### Technical Data

Torque:	88 lb-in (10 Nm)
Runtime for 90°:	125 seconds at 60 Hz opening and closing 150 seconds at 50 Hz opening and closing
Frequency:	50/60 Hz
Power consumption:	3.3 VA (modulating) 2.3 VA (three-position)
Equipment rating (24 Vac):	Class 2 per UL/CSA
Noise level:	<35 dBA (running)
Angle of rotation:	90° nominal, 95° max.
Shaft dimensions:	3/8 to 5/8-in. (8 to 16 mm) dia. 3/4-in. (20 mm) min. length
Operating temperature:	-22 to 130°F (-30 to 55°C)
Storage temperature:	-22 to 140°F (-30 to 60°C)
Ambient humidity:	95% rh (non-condensing)
Pre-cabled connection:	18 AWG, 3 ft (0.9 m), or 6-ft (1.8 m) long
Enclosure:	NEMA 2, IP54 per EN60529
Material:	Durable plastic
Agency listings:	UL873, C-UL C22.2 No. 24-93
<b>CE</b> Conformity:	
Electromagnetic Compatibility (EMC)	89/336/EEC
Emissions Standards	EN 50081-1
Immunity standards	EN 50082-2
Gear Lubrication:	Silicone free
Weight:	1.06 lb (0.48 kg)

### Description

The OpenAir™ direct-coupled, non-spring return electronic damper actuators provide modulating and three-position control of building HVAC dampers.



### Features

- Compact, lightweight design
- Models available with dual independently adjustable auxiliary switches
- All modulating models offer built-in feedback
- Floating control models available with feedback potentiometer
- Manual override
- Mechanical range adjustment capability
- Easily visible position indicator
- Precabled
- Plenum cable
- Synchronous motor technology
- UL873 and C-UL (C22.2 No. 24-93) listed
- **CE** certified

### Typical Specifications

Non-spring return damper actuators shall be the direct-coupled type that requires no connecting linkages. The non-spring return actuators under 100 lb-in shall be capable of direct mounting to a shaft up to a 5/8-inch diameter. Actuators shall provide stall protection throughout the full range of rotation. All non-spring return actuators shall be capable of both clockwise and counterclockwise operation. All actuators shall hold position in the event of a power failure. All actuators shall return to the 0 position in the event only the control signal is lost. All actuators shall provide a means of manually positioning the output coupling in the absence of power. Dual independently adjustable auxiliary switches must be integral to the actuator. All actuators must be precabled and provide an easily readable high contrast yellow on black position indicator. All actuators shall be UL873 and CSA22.2 listed, CE certified, and manufactured under ISO 9002 and ISO 14000 procedures. Actuators shall be designed for a minimum of 50,000 full stroke cycles at the actuators rated torque and temperatures. Actuators shall be as manufactured by Siemens Building Technologies.

### Dimensions in inches (millimeters)

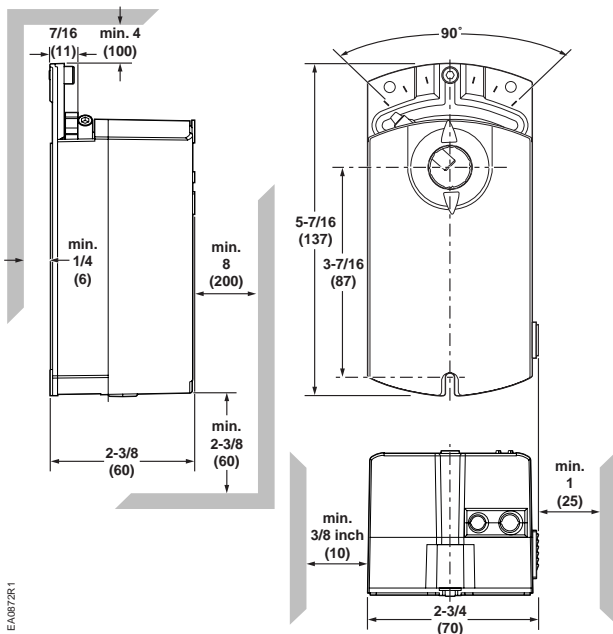

### Wiring Diagrams

0 to 10 Vdc, 24 Vac:

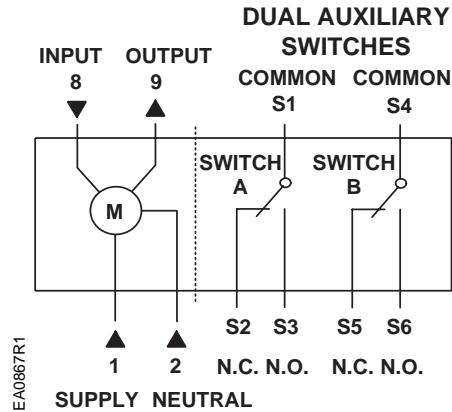

Three-Position, 24 Vac:

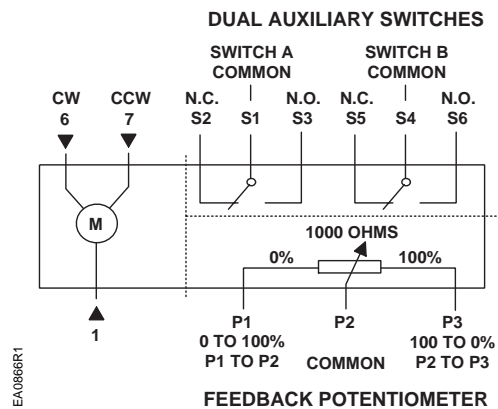

Information in this publication is based on current specifications. The company reserves the right to make changes in specifications and models as design improvements are introduced. Other product or company names mentioned herein may be the trademarks of their respective owners. © 2005 Siemens Building Technologies, Inc.