

**Minimum 27 in-lb torque**

- For damper areas up to 6.8 sq-ft\*



All Actuators have BDCM

**LU Series - At A Glance**

		<i>LUB(X)24-3 (p. 258)</i>	<i>LUB(X)24-SR (p. 260)</i>	<i>LUX24-MFT (p. 262)</i>
Basic Product		•	•	
Flexible Product		•	•	•
Torque	27 in-lb [3 Nm]	•	•	•
Angle of Rotation	Endless	•		•
	330 degrees		•	
Power Supply	24 VAC/DC	•	•	•
Control Input	On/Off, Floating Point	•		
	2 to 10 VDC (4 to 20mA)		•	
	Multi-Function Technology			•
Feedback	None	•		
	2 to 10 VDC		•	
	Variable (0 to 10 VDC)			•
Running Time	150 seconds	•	•	
	Adj. 75 to 150 seconds	•	•	•
Wiring	Plenum Rated Cable	•	•	•
	Appliance Rated Cable			
	Terminal Strip			
	Conduit Fitting	•	•	•

Installation and Operation... (page 265).

\*Based on 4 in-lb/ft<sup>2</sup> damper torque loading. Parallel blade. No edge seals.

K20901 - 01/09 - Subject to change. © Belimo Aircontrols (USA), Inc.

# A CLOSER LOOK...

- Brushless DC Motor for Added Accuracy and Controllability.
- Cut Labor Costs with Simple Direct Coupling.
- Don't Worry about Actuator Burn-Out; Belimo is Overload Proof throughout Rotation.
- Enjoy Added Flexibility with Mechanical Stops to Adjust Angle of Rotation (ZDB-LU).
- Need to Change Control Direction? Do it easily with a Simple Switch.
- Easily Accessible Manual Override Button helps you Pre-Tension Damper Blades.
- Standard 3ft Plenum Rated Cable and Conduit Connector Provided on Basic Models.
- Added Flexibility to Select Clamp, Electrical Connection, and Running Time to fit your Specific Application with Belimo's New Flexible Line of Actuators.

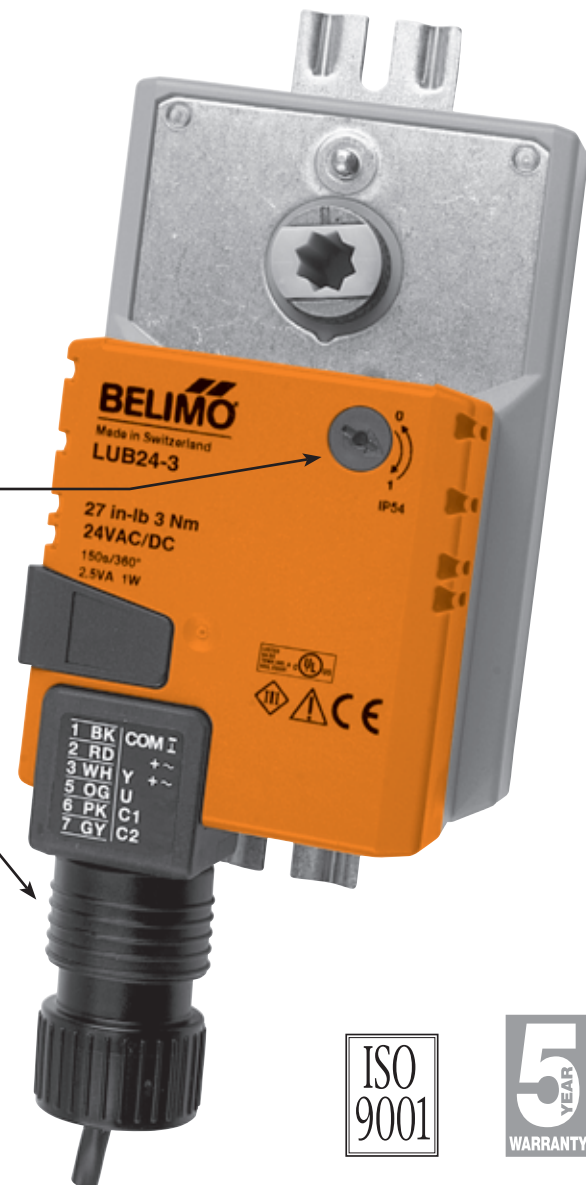

## The Belimo Difference

- **Customer Commitment.**  
Extensive product range. Application assistance.  
Same-day shipments. Free technical support. Five year warranty.
- **Low Installation and Life-Cycle Cost.**  
Easy installation. Accuracy and repeatability.  
Low power consumption. No maintenance.
- **Long Service Life.**  
Components tested before assembly. Every product tested before shipment.  
30+ years direct coupled actuator design.

K20901 - 01/09 - Subject to change. © Belimo Aircontrols (USA), Inc.

# LUB(X)24-3

On/Off, Floating Point Control, Non-Spring Return, 360°, 24V

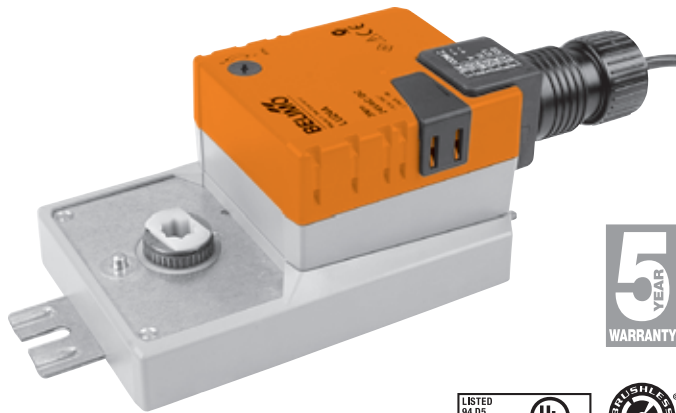

Technical Data	LUB(X)24-3
Power Supply	24 VAC ± 20% 50/60 Hz 24 VDC ± 20%
Power Consumption	1 W (0.5 W)
Transformer Sizing	2.5 VA (Class 2 power source)
Electrical Connection	18 GA plenum rated cable 1/2" conduit connector Protected NEMA 2 (IP54) □ 3 ft [1m] □ 10 ft [3m] □ 16 ft [5m]
Overload Protection	electronic throughout full rotation
Control	On/Off, Floating Point
Input Impedance	600 Ω
Angle of Rotation	endless adjustable 0 to 330° with ZDB-LU
Torque	27 in-lb [3 Nm]
Direction of Rotation	reversible with  switch
Manual Override	external push button
Running Time (per 360 degrees)	□ 150 seconds (2.5 rpm) □ 95 seconds (1.6 rpm) □ 75 seconds (1.25 rpm)
Humidity	5 to 95% RH non condensing (EN 60730-1)
Ambient Temperature	-22°F to 122°F [-30°C to 50°C]
Storage Temperature	-40°F to 176°F [-40°C to 80°C]
Housing	NEMA 2, IP54, UL enclosure type 2
Housing Material	UL94-5VA
Agency Listings†	cULus acc. to UL 60730-1A/-2-14, CAN/CSA E60730-1:02, CE acc. to 2004/108/EEC and 2006/95/EC
Noise Level (max)	35dB(A)
Servicing	maintenance free
Quality Standard	ISO 9001
Weight	1.43 lbs [650 g]

†Rated Impulse Voltage 800V, Type of action 1, Control Pollution Degree 3.

Torque min. 27 in-lb for control of damper surfaces up to 6.8 sq. ft.

## Application

For on/off and floating point control of dampers in HVAC systems. Actuator sizing should be done in accordance with the damper manufacturer's specifications.

Control is floating point from a triac or relay, or on/off from an auxiliary contact from a fan motor contactor, controller, or manual switch.

## Operation

The actuator is not provided with and does not require any limit switches, but is electronically protected against overload. The anti-rotation strap supplied with the actuator will prevent lateral movement.

The LUB(X) series provides 330° of rotation with angle of rotation limiter, ZDB-LU. Without ZDB-LU the LUB(X) provides endless rotation.

When reaching the damper or actuator end position, the actuator automatically stops. The gears can be manually disengaged with a button on the actuator cover.

The LUB24-3 actuators use a sensorless Brushless DC motor, which is controlled by an Application Specific Integrated Circuit (ASIC). The ASIC monitors and controls the actuator's rotation and provides a digital rotation sensing (DRS) function to prevent damage to the actuator in a stall condition. Power consumption is reduced in holding mode.

## Dimensions (Inches [mm])

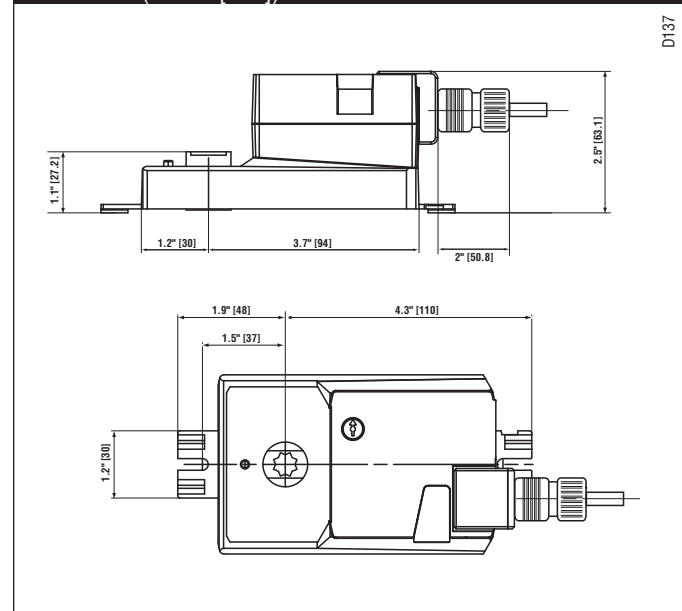

K20901 - 01/09 - Subject to change. © Belimo Aircontrols (USA), Inc.

### Accessories

K-LU	1/3" to 1/2" [8 to 12 mm] Shaft Clamp
ZDB-LU	Angle of Rotation Limiter with Scaling
P370	Shaft Mount Auxiliary Switch

**NOTE:** When using LUB(X)24-3 actuators, only use accessories listed on this page.

### Typical Specification

Floating point, on/off control damper actuators shall be electronic type, which require no crankarm and linkage. Actuators shall have Brushless DC motor technology and be protected from overload at all positions of linear stroke. Actuators shall have reversing switch and manual override on the cover. Run time shall be constant and independent of torque. Actuators shall be cUL Approved, have a 5-year warranty, and be manufactured under ISO 9001 International Quality Control Standards. Actuators shall be as manufactured by Belimo.

### Wiring Diagrams

#### ✂️ INSTALLATION NOTES

⚠️ 1 Provide overload protection and disconnect as required.

⚠️ 3 Actuators may also be powered by 24 VDC.

#### 📄 APPLICATION NOTES

◆ Meets cULus or UL and CSA Standard requirements without the need of an electrical ground connection.

#### ⚠️ WARNING Live Electrical Components!

During installation, testing, servicing and troubleshooting of this product, it may be necessary to work with live electrical components. Have a qualified licensed electrician or other individual who has been properly trained in handling live electrical components perform these tasks. Failure to follow all electrical safety precautions when exposed to live electrical components could result in death or serious injury.

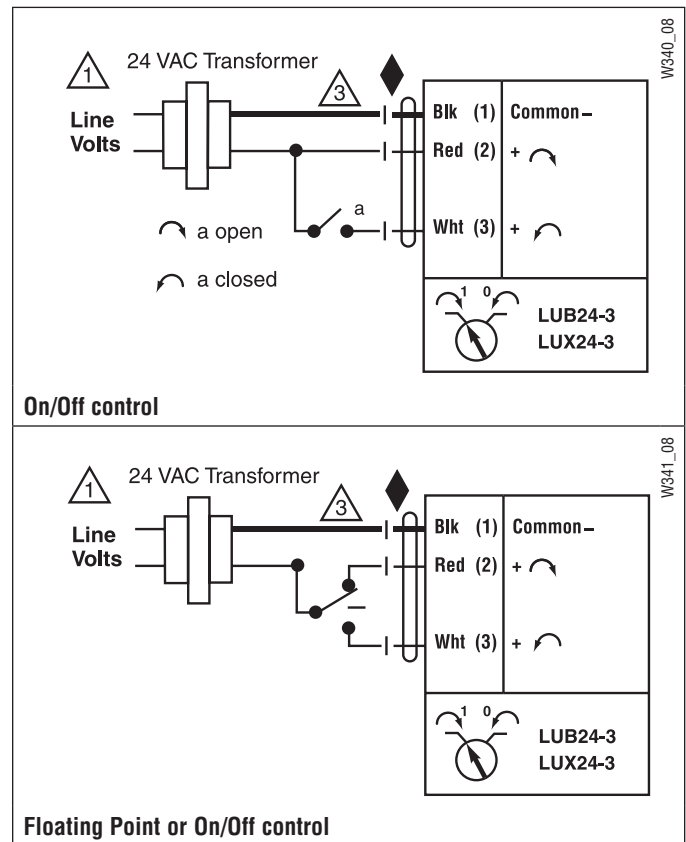

# LUB(X)24-SR

Proportional Control, Non-Spring Return, 360°, 24V, for 2 to 10 VDC and 4 to 20 mA

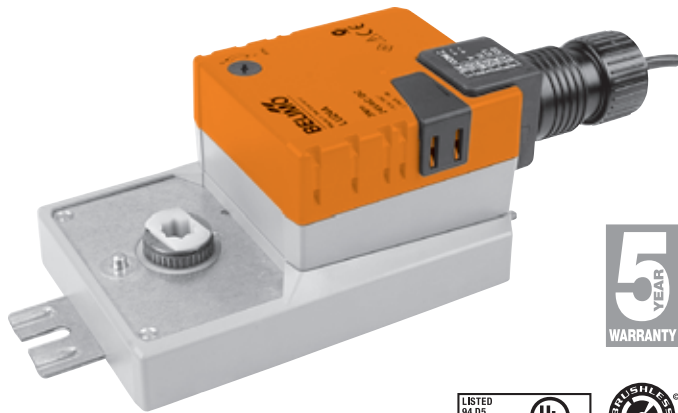

Technical Data	LUB(X)24-SR
Power Supply	24 VAC ± 20% 50/60 Hz 24 VDC ± 20%
Power Consumption	1.5 W (0.5 W)
Transformer Sizing	3 VA (Class 2 power source)
Electrical Connection	18 GA plenum rated cable 1/2" conduit connector Protected NEMA 2 (IP54) □ 3 ft [1m] □ 10 ft [3m] □ 16 ft [5m]
Overload Protection	electronic throughout full rotation
Operating Range Y	2 to 10 VDC, 4 to 20 mA
Input Impedance	100 kΩ (0.1 mA), 500 Ω
Feedback Output U	2 to 10 VDC (max 0.5 mA)
Angle of Rotation	330°
Torque	27 in-lb [3 Nm]
Direction of Rotation	reversible with  switch Actuator will move: =CCW with decreasing control signal (10 to 2V) =CW with decreasing control signal (10 to 2V)
Manual Override	external push button
Running Time (per 360 degrees)	□ 150 seconds (2.5 rpm) □ 95 seconds (1.6 rpm) □ 75 seconds (1.25 rpm)
Humidity	5 to 95% RH non condensing (EN 60730-1)
Ambient Temperature	-22°F to 122°F [-30°C to 50°C]
Storage Temperature	-40°F to 176°F [-40°C to 80°C]
Housing	NEMA 2, IP54, UL enclosure type 2
Housing Material	UL94-5VA
Agency Listings†	cULus acc. to UL 60730-1A/-2-14, CAN/CSA E60730-1:02, CE acc. to 2004/108/EEC and 2006/95/EC
Noise Level (max)	35dB(A)
Servicing	maintenance free
Quality Standard	ISO 9001
Weight	1.43 lbs [650 g]

†Rated Impulse Voltage 800V, Type of action 1, Control Pollution Degree 3.

Force min. 27 in-lb for control of damper surfaces up to 6.8 sq. ft.

## Application

For proportional modulation of dampers in HVAC systems. Actuator sizing should be done in accordance with the damper manufacturer's specifications.

The actuator operates in response to a 2 to 10 VDC, or with the addition of a 500 Ω resistor, a 4 to 20 mA control input from an electronic controller or positioner. A 2 to 10 VDC feedback signal is provided for position indication or master-slave applications.

## Operation

The actuator is not provided with and does not require any limit switches, but is electronically protected against overload. The anti-rotation strap supplied with the actuator will prevent lateral movement.

The LUB(X) series provides 330° of rotation with angle of rotation limiter, ZDB-LU.

When reaching the damper or actuator end position, the actuator automatically stops. The gears can be manually disengaged with a button on the actuator cover.

The LUB(X)24-SR actuators use a Brushless DC motor, which is controlled by an Application Specific Integrated Circuit (ASIC). The ASIC monitors and controls the actuator's rotation and provides a digital rotation sensing (DRS) function to prevent damage to the actuator in a stall condition. The actuator may be stalled anywhere in its normal rotation without the need of mechanical end switches. Power consumption is reduced in holding mode.

## Dimensions (Inches [mm])

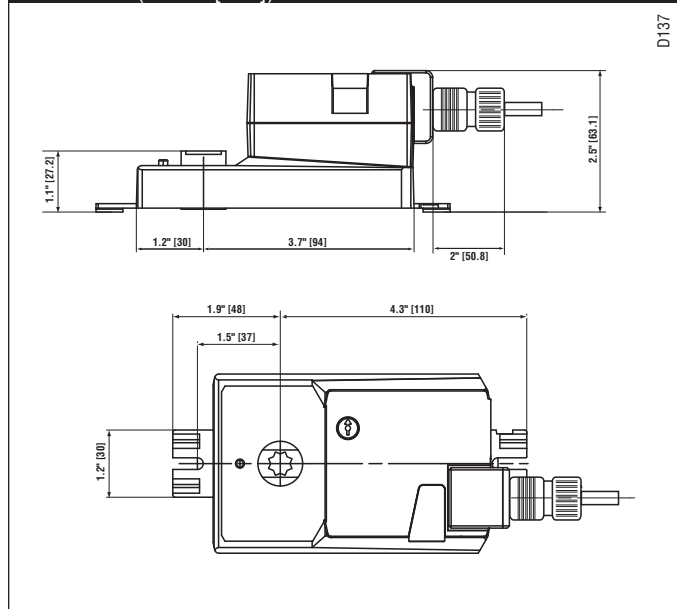

K20901 - 01/09 - Subject to change. © Belimo Aircontrols (USA), Inc.

### Accessories

K-LU	1/3" to 1/2" [8 to 12 mm] Shaft Clamp
P370	Shaft Mount Auxiliary Switch
SGA24	Min Positioners in NEMA 4 Housing
SGF24	Min Positioners for Flush Panel Mounting
PTA-250	Pulse Width Modulation Interface
IRM-100	Input Rescaling Module
ADS-100	Analog to Digital Switch
ZG-R01	Resistor for 4 to 20 mA Conversion
NSV24 US	Battery Back-Up Module
ZG-X40	Transformer

**NOTE:** When using LUB(X)24-SR actuators, only use accessories listed on this page.

### Typical Specification

Proportional control damper actuators shall be electronic type, which require no crankarm and linkage. Actuators must provide proportional damper control in response to a 2 to 10 VDC or, with the addition of a 500 Ω resistor, a 4 to 20 mA control input from an electronic controller or positioner. Actuators shall have Brushless DC motor technology and be protected from overload at all angles of rotation. Actuators shall have reversing switch and manual override on the cover. Run time shall be constant and independent of torque. A 2 to 10 VDC feedback signal shall be provided for position indication. Actuators shall be cUL Approved, have a 5-year warranty, and be manufactured under ISO 9001 International Quality Control Standards. Actuators shall be as manufactured by Belimo.

### Wiring Diagram

#### ✂ INSTALLATION NOTES

- 1 Provide overload protection and disconnect as required.
- 2 **CAUTION Equipment damage!**  
Actuators may be connected in parallel.  
Power consumption and input impedance must be observed.
- 3 Actuators may also be powered by 24 VDC.
- 5 Only connect common to neg. (-) leg of control circuits.

#### 📄 APPLICATION NOTES

- ◆ The ZG-R01 500 Ω resistor converts the 4 to 20 mA control signal to 2 to 10 VDC, up to 2 actuators may be connected in parallel.

#### ⚠ WARNING Live Electrical Components!

During installation, testing, servicing and troubleshooting of this product, it may be necessary to work with live electrical components. Have a qualified licensed electrician or other individual who has been properly trained in handling live electrical components perform these tasks. Failure to follow all electrical safety precautions when exposed to live electrical components could result in death or serious injury.

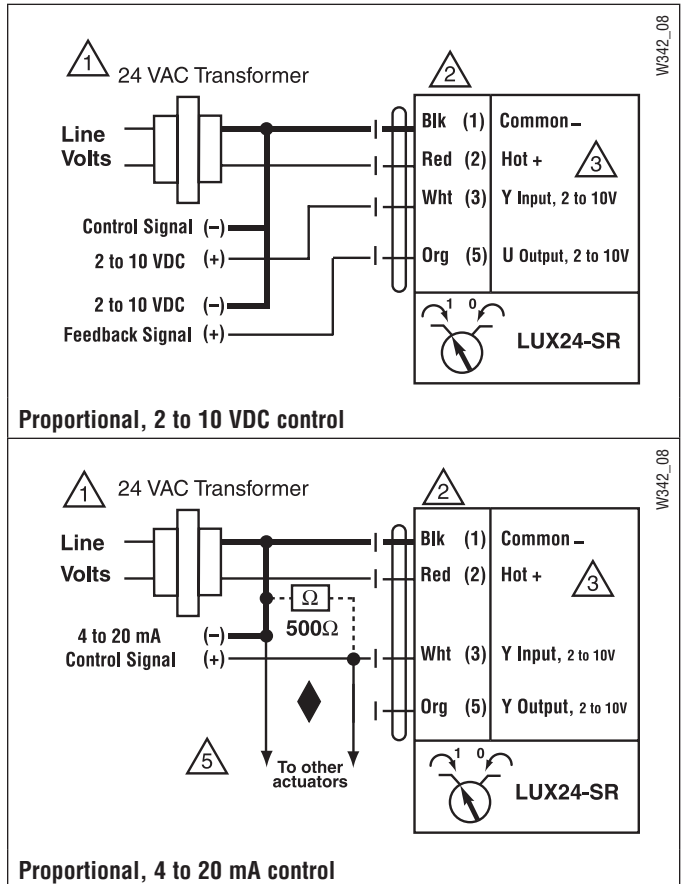



Technical Data	LUX24-MFT
Power Supply	24 VAC ± 20% 50/60 Hz 24 VDC ± 10%
Power Consumption	2.5 W (1.2 W)
Transformer Sizing	5 VA (Class 2 power source)
Electrical Connection	18 GA plenum rated cable 1/2" conduit connector Protected NEMA 2 (IP54) □ 3 ft [1m] □ 10 ft [3m] □ 16 ft [5m]
Overload Protection	electronic throughout full rotation
Operating Range Y	2 to 10 VDC, 4 to 20 mA (default) Variable (VDC, PWM, Floating Point, On/Off)
Input Impedance	100 kΩ (0.1 mA), 500 Ω 1500 Ω (PWM, Floating Point, On/Off)
Feedback Output U	2 to 10 VDC (max 0.5 mA) VDC Variable
Angle of Rotation	endless, adjustable with ZDB-LU electronically variable
Torque	27 in-lb [3 Nm]
Direction of Rotation	reversible with  switch
Position Indication	reflective visual indicator (snap-on)
Manual Override	external push button
Running Time (per 360 degrees)	150 seconds (2.5 rpm, default) Variable, 75 to 150 seconds (1.25 to 2.5 rpm)
Humidity	5 to 95% RH non condensing (EN 60730-1)
Ambient Temperature	-22°F to 122°F [-30°C to 50°C]
Storage Temperature	-40°F to 176°F [-40°C to 80°C]
Housing	NEMA 2, IP54, UL enclosure type 2
Housing Material	UL94-5VA
Agency Listings†	cULus acc. to UL 60730-1A/-2-14, CAN/CSA E60730-1:02, CE acc. to 2004/108/EEC and 2006/95/EC
Noise Level	<35dB(A)
Servicing	maintenance free
Quality Standard	ISO 9001
Weight	1.43 lbs [650 g]

†Rated Impulse Voltage 800V, Type of action 1, Control Pollution Degree 3.

**Torque min. 27 in-lb for control of damper surfaces up to 6.8 sq ft.**

### Application

For proportional modulation of dampers in HVAC systems. Actuator sizing should be done in accordance with the damper manufacturer's specifications.

The default parameters for 2 to 10 VDC applications of the ...MFT actuator are assigned during manufacturing. If necessary, custom versions of the actuators can be ordered. The parameters can be changed by two means: pre-set and custom configurations from Belimo or on-site configurations using the Belimo PC-Tool software.

### Operation

The actuator is not provided with and does not require any limit switches, but is electronically protected against overload. The anti-rotation strap supplied with the actuator will prevent lateral movement.

The LUB series provides 330° of rotation with angle of rotation limiter, ZDB-LU. Without ZDB-LU the LUB24-3 provides endless rotation.

When reaching the damper or actuator end position, the actuator automatically stops. The gears can be manually disengaged with a button on the actuator cover.

The LUX24-MFT... actuators use a Brushless DC motor, which is controlled by an Application Specific Integrated Circuit (ASIC). The ASIC monitors and controls the actuator's rotation and provides a digital rotation sensing (DRS) function to prevent damage to the actuator in a stall condition. Power consumption is reduced in holding mode.

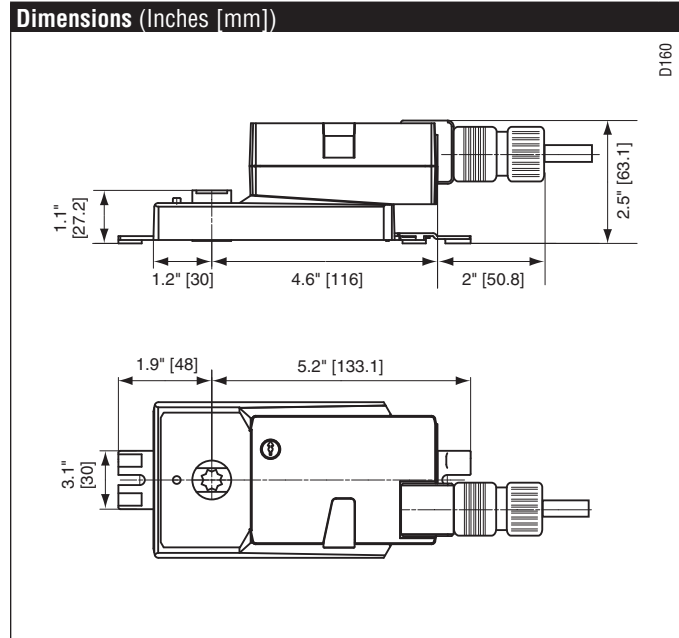

K20901 - 01/09 - Subject to change. © Belimo Aircontrols (USA), Inc.

### Accessories

K-LU	1/3" to 1/2" [8 to 12 mm] Shaft Clamp
ZDB-LU	Angle of Rotation Limiter with Scaling
P370	Shaft Mount Auxiliary Switch
SGA24	Min Positioners in NEMA 4 Housing
SGF24	Min Positioners for Flush Panel Mounting
PTA-250	Pulse Width Modulation Interface
IRM-100	Input Rescaling Module
ADS-100	Analog to Digital Switch
ZG-R01	Resistor for 4 to 20 mA Conversion
NSV24 US	Battery Back-Up Module
ZG-X40	Transformer

**NOTE:** When using LUX24-MFT actuators, only use accessories listed on this page.

### Typical Specification

Proportional control damper actuators shall be electronic direct-coupled type, which require no crankarm and linkage and be capable of direct mounting to a shaft from 1/4" to 5/8". Actuators must provide control in response to a control input from an electronic controller or positioner. Actuators shall have Brushless DC motor technology and be protected from overload at all angles of rotation. Actuators shall have reversing switch and manual override on the cover. Run time shall be constant and independent of torque. Actuators shall be cULus listed, have a 5-year warranty, and be manufactured under ISO 9001 International Quality Control Standards. Actuators shall be as manufactured by Belimo.

### Wiring Diagrams

#### ✂️ INSTALLATION NOTES

- 1 Provide overload protection and disconnect as required.
- 2 **CAUTION Equipment damage!**  
Actuators may be connected in parallel if not mechanically mounted to the same shaft. Power consumption and input impedance must be observed.
- 3 Actuators may also be powered by 24 VDC.
- 4 Position feedback cannot be used with Triac sink controller. The actuator internal common reference is not compatible.
- 5 Control signal may be pulsed from either the Hot (source) or the Common (sink) 24 VAC line.
- 8 Contact closures A & B also can be triacs.
- 9 A & B should both be closed for triac source and open for triac sink. For triac sink the common connection from the actuator must be connected to the hot connection of the controller.

#### 📄 APPLICATION NOTES

- ◆ The ZG-R01 500 Ω resistor may be used.

#### ⚠️ WARNING Live Electrical Components!

During installation, testing, servicing and troubleshooting of this product, it may be necessary to work with live electrical components. Have a qualified licensed electrician or other individual who has been properly trained in handling live electrical components perform these tasks. Failure to follow all electrical safety precautions when exposed to live electrical components could result in death or serious injury.

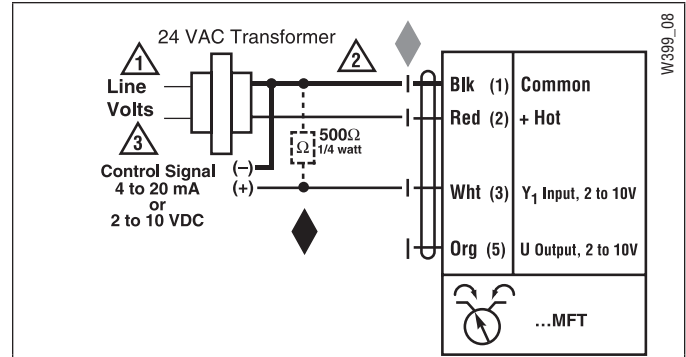

VDC/4-20 mA

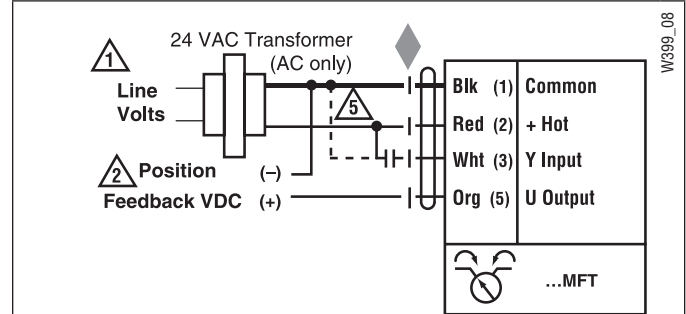

PWM

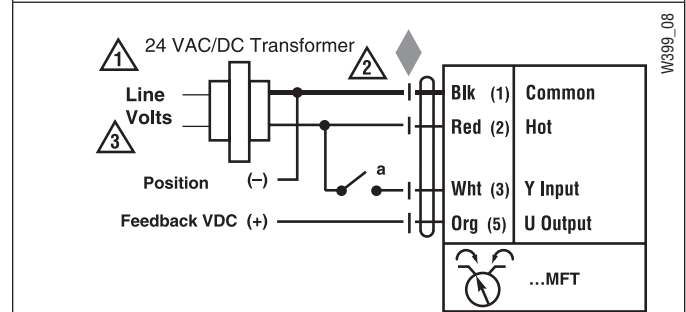

On/Off control

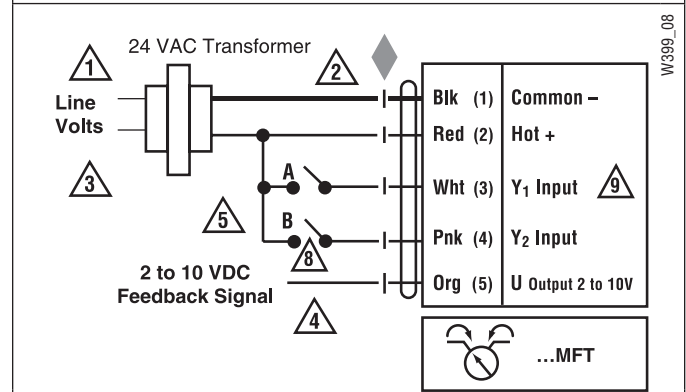

Floating Point control