

MF4E-60x3x Series

Non-Spring Return EconoDrive™ Floating Actuator

The MF4E-6043x series 35 lb-in. (3.3 N-m) and MF4E-6083x series 70 lb-in. (6.6 N-m) non-spring return, direct-coupled actuators provide affordable floating control for dampers and rotary valves. They are suitable for use with single pole, double throw (SPDT) floating thermostats or Direct Digital Control (DDC) systems.

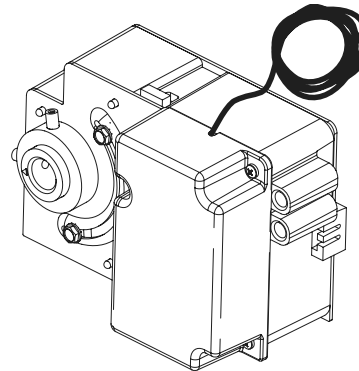

Features:

- Visual position indicator.
- Adjustable stroke limit in both clockwise (CW) and counterclockwise (CCW) directions.
- Magnetic coupling prevents overload at any stroke.
- 35 and 70 lb-in. (4 and 8 N-m) torque models.
- Provides 95° rotation (stroke).
- Direct mount on 1/2 in. diameter shafts (3/8 in. shafts with use of an adapter).
- Manual override for free shaft rotation to any position, 0° to 95°.
- Can be mounted in any position.
- Rated for use in plenums.
- Rugged design for extended actuator life.
- Integral strain relief for integral 10 foot plenum rated cable.
- Synchronous motor provides consistent timing.

Model Chart							
Model	Actuator Power Input				Typical Timing in Seconds for 90° Stroke at 70°F (21°C) ^a		Output Torque Rating lb-in. (N-m)
	Voltage	Running		Watts	50 Hz	60 Hz	
		50 Hz	60 Hz				
MF4E-60430-100	24 Vac +20%/-15%	2.0	2.0	2.0	108	90	35 (4)
MF4E-60830-100							70 (8)

^a Timing is measured with no load applied to the actuator.

Specifications

Inputs	
Control signal	Floating control, 24 Vac +20%/-15%.
Power Input	See Model Chart. All 24 Vac circuits are Class 2.
Electrical Connections	10 ft plenum rated cable.
Outputs	
Mechanical	Stroke: $95^{\circ} \pm 3^{\circ}$ of rotation. Stroke limit is adjustable 0° to 95° in both clockwise (CW) and counterclockwise (CCW) directions.
	Manual Override: Allows free shaft rotation to any position from 0° to 95° .
	Mounting: Mounts directly onto a 1/2 in. (13 mm) round shaft. Two mounting screws allows mounting onto the shaft in any position. Minimum 2 in. (51 mm) shaft length required. Mounting onto a 3/8 in. (9.5 mm) diameter shaft requires an AM-135 adapter kit.
	Actuator Timing for 90° Stroke: See Model Chart.
	Torque Ratings: See Model Chart.
	Position Indicator: Visual indicator.
	Nominal Damper Area: Actuator sizing should be done in accordance with the damper manufacturer's recommendations for the given flow condition.
Direction of Rotation: Clockwise (CW) or counterclockwise (CCW) rotation.	
Environment	
Ambient temperature limits	Shipping and Storage: -40 to 160°F (-40 to 71°C). Operating: -22 to 140°F (-30 to 60°C).
Humidity	5 to 95% RH, non-condensing.
Locations	NEMA 1 (IEC IP30).
Dimensions	4-5/32 L x 3-17/32 W x 2-3/4 D in. (110 x 90 x 70 mm).
Agency Listings	
UL 873	Underwriters Laboratories (File # E9429) Category Temperature-Indicating and Regulating Equipment. Plenum rated.
CUL	UL Listed for use in Canada by Underwriters Laboratories. Canadian Standards C22.2 No. 24-93.
European Community	EN 61326.
Australia	This product meets requirements to bear the C-Tick Mark.
General Instructions	Refer to F-27108.

Accessories

Model No.	Description
AM-135	3/8 in. (9.5 mm) shaft adapter.
AM-675	Base mounting plate (used with AM-714).
AM-714	Weather shield.
AM-769	Terminal cover guard.

MF4E-60x3x Series

Typical Applications

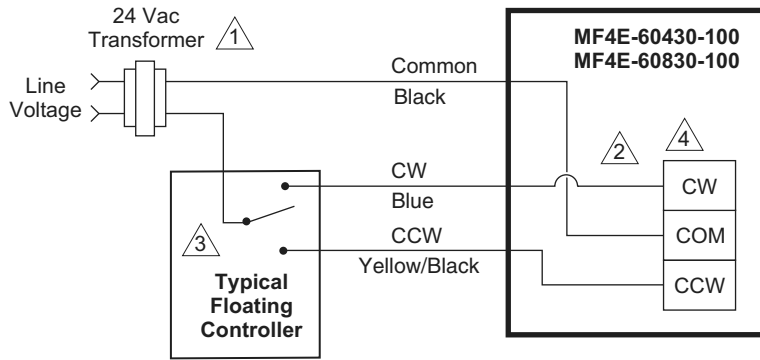

- 1 Provide overload protection and a disconnect as required.
- 2 Actuators may be wired in parallel only if they have the same rotational speed (stroke timing). When doing so, be sure to observe power consumption limits.
- 3 To increase actuator life, design the system with a time-out feature that removes power from the actuator between uses. For example, such a device may stop controller output after powering the actuator in one direction for 3 minutes or more.
- 4 CW/CCW drive direction is as viewed from the top of the actuator.

Figure 1 Floating Point Control Wiring Diagram.

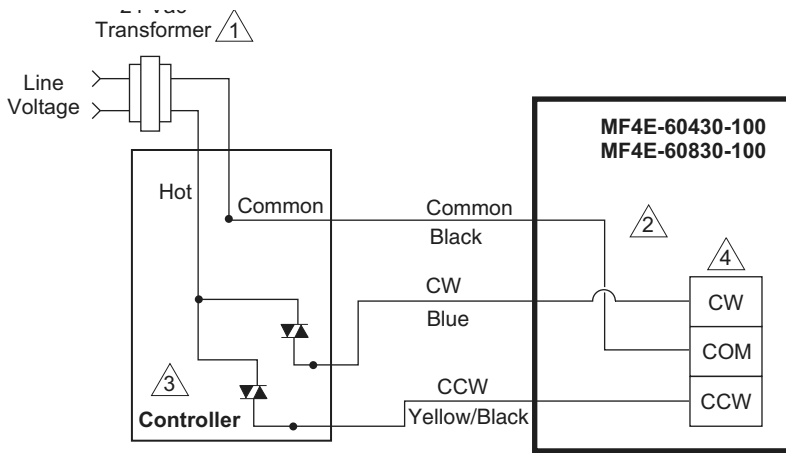

- 1 Provide overload protection and a disconnect as required.
- 2 Actuators may be wired in parallel only if they have the same rotational speed (stroke timing). When doing so, be sure to observe power consumption limits.
- 3 To increase actuator life, design the system with a time-out feature that removes power from the actuator between uses. For example, such a device may stop controller output after powering the actuator in one direction for 3 minutes or more.
- 4 CW/CCW drive direction is as viewed from the top of the actuator.

Figure 2 Triac Source Wiring Diagram.

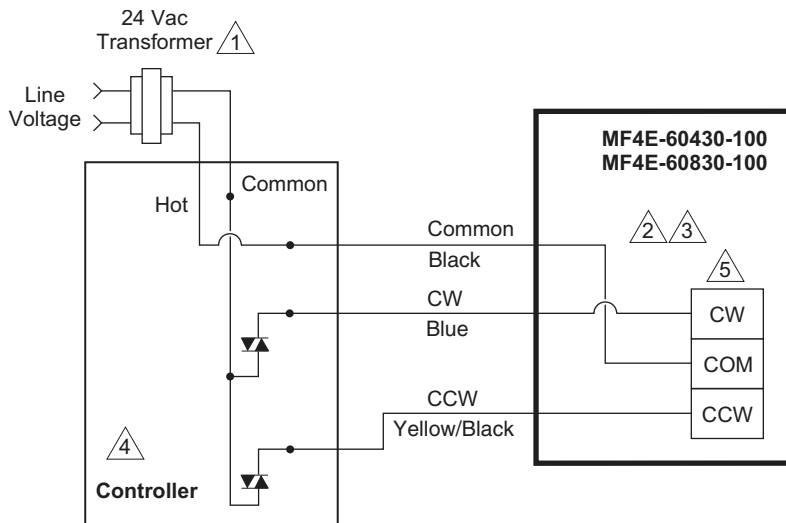

- 1 Provide overload protection and a disconnect as required.
- 2 Actuators may be wired in parallel only if they have the same rotational speed (stroke timing). When doing so, be sure to observe power consumption limits.
- 3 The Common connection from the actuator must be connected to the Hot connection of the controller.
- 4 To increase actuator life, design the system with a time-out feature that removes power from the actuator between uses. For example, such a device may stop controller output after powering the actuator in one direction for 3 minutes or more.
- 5 CW/CCW drive direction is as viewed from the top of the actuator.

Figure 3 Triac Sink Wiring Diagram.