

## Minimum 60 in-lb torque

- For damper areas up to 15 sq-ft\*

## Applications

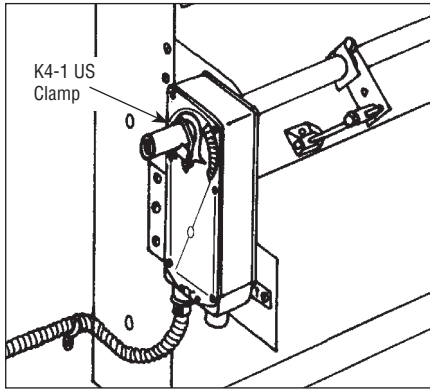

Mount directly to 1.05" jackshafts with accessory clamp.

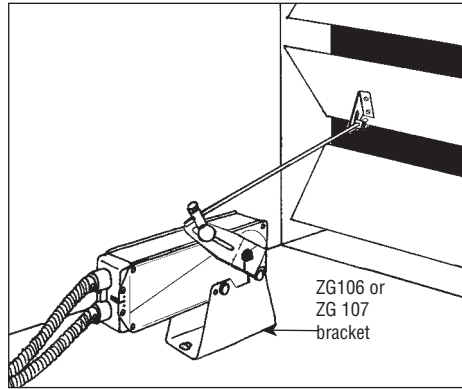

Linkage is available when direct coupling is not possible. (See Mounting Methods Guide 5.1 and Mechanical Accessories section)



All Actuators have BDCM

## NF Series - At A Glance

	<i>NF24 US (p. 46)</i>	<i>NF24-S US (p. 46)</i>	<i>NF24-S2 US (p. 46)</i>	<i>NF120 US (p. 48)</i>	<i>NF120-S US (p. 48)</i>	<i>NF24-SR US (p. 50)</i>	<i>NF24-SR-S US (p. 50)</i>	<i>NF24-MFT US (p. 52)</i>
Torque:	60 in-lb	●	●	●	●	●	●	●
Power supply:	24 VAC	●	●	●	●	●	●	●
	120 VAC			●	●			
Control signal:	On/Off	●	●	●	●			
	proportional 2 to 10 VDC					●	●	
	Multi-function**							●
Feedback signal:	2 to 10 VDC					●	●	
	VDC variable**							●
Running time motor:	<75 sec	●	●	●	●			
	150 sec constant					●	●	
	Adj. 75 to 300 sec.***							●
	spring: <60 sec	●	●	●	●	●	●	●
Brushless DC Motor						●	●	
External direction of rotation switch						●	●	●
Appliance rated cable, 18 GA	●	●	●	●	●	●	●	●
Built-in auxiliary switch	1SPDT	●			●		●	
	2 SPDT		●					

Installation instructions .....(p. 54-57)

General wiring.....(p. 60)

Start-up and checkout.....(p. 61)

\*Based on 4 in-lb/ft<sup>2</sup> damper torque loading. Parallel blade. No edge seals. \*\*Default 2 to 10 VDC. \*\*\*Default 150 seconds.

# A CLOSER LOOK...

- Cut labor costs with simple direct coupling.
- True mechanical spring return – the most reliable fail-safe.
- Mount for clockwise or counterclockwise fail-safe.
- Check damper position easily with clear position indicator.
- Don't worry about actuator burn-out. Belimo is overload-proof throughout rotation.
- Easy mechanical stop to adjust angle of rotation (add ZDB-AF2 US accessory).
- Need to change control direction? Do it easily with a simple switch (modulating actuators).
- Golden Point breather membrane optimizes performance in harsh airstream environments.
- Built-in auxiliary switch(s) is easy to use, offers feedback or signal for additional device (NF24-S2 US has two switches, the NF24-S US and NF120-S US have one switch).
- Microprocessor-controlled brushless DC motor increases actuator life span and reliability, provides constant running time (modulating actuators).
- Rugged metal housing withstands rough handling in the mechanical room.
- 3 ft. appliance rated cable and conduit connector eases installation.

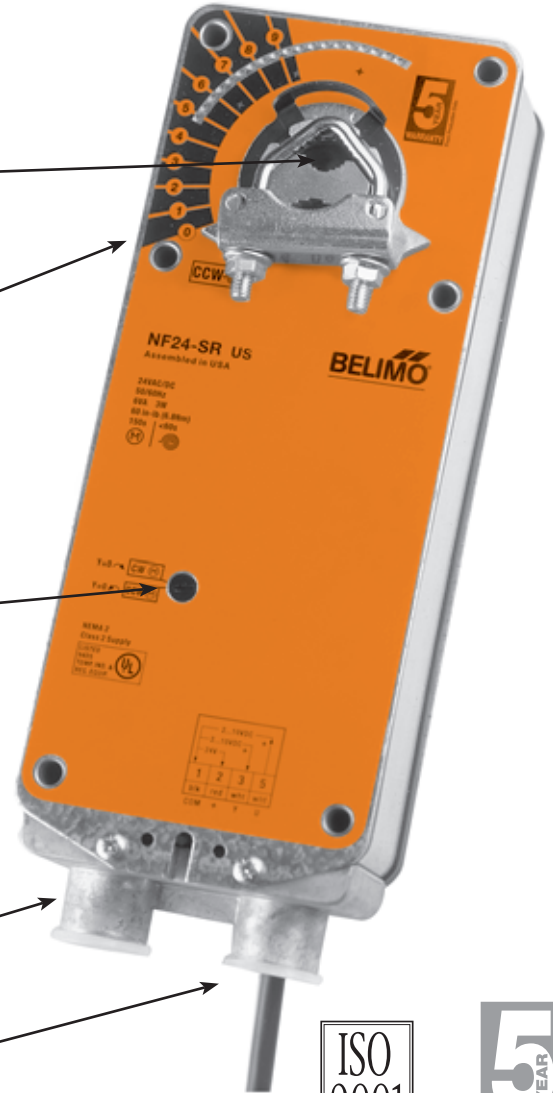

## The Belimo Difference

- **Customer Commitment.**  
Extensive product range. Application assistance.  
Same-day shipments. Free technical support. Five year warranty.
- **Low Installation and Life-Cycle Cost.**  
Easy installation. Accuracy and repeatability.  
Low power consumption. No maintenance.
- **Long Service Life.**  
Components tested before assembly. Every product tested before shipment.  
30+ years direct coupled actuator design.

K20901 - 01/09 - Subject to change. © Belimo Aircontrols (USA), Inc.

# NF24(-S,-S2) US

On/Off, Spring Return Fail-Safe, 24 V



Technical Data		NF24(-S,-S2) US
Power supply		24 VAC ± 20% 50/60 Hz 24 VDC ± 10%
Power consumption	running	5 W
	holding	2.6 W
Transformer sizing		8 VA (class 2 power source)
Electrical connection		3 ft, 18 GA appliance cable 1/2" conduit connector
Overload protection		Electronic throughout 0 to 95° rotation
Electrical protection		Auxiliary switches are double insulated
Angle of rotation		95°, adjustable 30 to 95° w/ accessories
Torque		60 in-lb [7 Nm] constant torque
Direction of rotation		reversible with CW/CCW mounting
Position indication		visual indicator, 0° to 95° (0° is spring return position)
Running time	motor	< 75 sec
	spring	< 60 sec
Humidity		5 to 95% RH non-condensing
Ambient temperature		-22°F to 122°F [-30°C to 50°C]
Storage temperature		-40°F to 176°F [-40°C to 80°C]
Housing		NEMA type 2 / IP54
Housing material		zinc coated steel
Agency listings		cULus acc. to UL 873 and CAN/CSA C22.2 No. 24-93
Noise level		max. 45 dB (A)
Servicing		maintenance free
Quality standard		ISO 9001
Weight		6.6 lbs (3.0 kg)
Technical Data		NF24 -S2 US

NF24-S US	
Auxiliary switch	1 x SPDT 7A (2.5A) @ 250 VAC, UL Approved adjustable 5° to 85°

NF24-S2 US	
Auxiliary switch	2 x SPDT 7A (2.5A) @ 250 VAC, UL Approved one set at +5°, one adjustable 25° to 85°

**Torque min. 60 in-lb, for control of air dampers**

## Application

For On/Off, fail-safe control of dampers in HVAC systems. Actuator sizing should be done in accordance with the damper manufacturer's specifications. Control is On/Off from an auxiliary contact, or a manual switch.

The actuator is mounted directly to a damper shaft up to 1.05" in diameter by means of its universal clamp. A crank arm and several mounting brackets are available for applications where the actuator cannot be direct coupled to the damper shaft.

## Operation

The NF series actuators provide true spring return operation for reliable fail-safe application and positive close off on air tight dampers. The spring return system provides constant torque to the damper with, and without, power applied to the actuator.

The NF series provides 95° of rotation and is provided with a graduated position indicator showing 0° to 95°.

The actuator may be stalled anywhere in its normal rotation without the need of mechanical end switches.

The NF24-S US version is provided with 1 built in auxiliary switch. This SPDT switch is provided for safety interfacing or signaling, for example, for fan start-up. The switching function is adjustable between 5° and 85°.

The NF24-S2 US version is provided with 2 built-in auxiliary switches. These SPDT switches are provided for safety interfacing or signaling, for example, for fan start-up. The switching function at the fail-safe position is fixed at +5°, the other switch function is adjustable between +25° to +85°.

## Dimensions (Inches [mm])

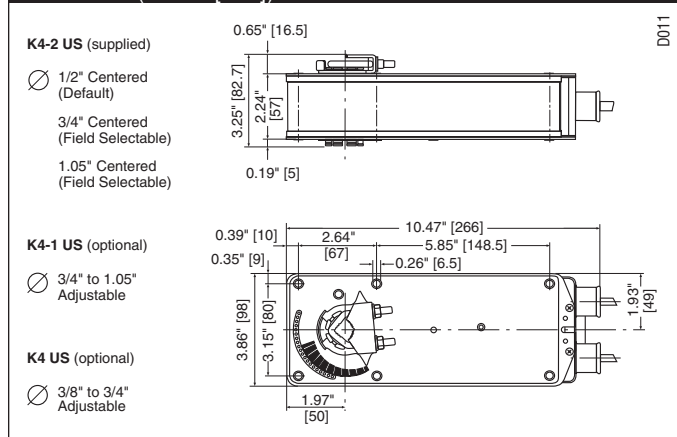

K20901 - 01/09 - Subject to change. © Belimo Aircontrols (USA), Inc.

### Accessories

AV 10-18	Shaft extension
IND-AF2	Damper position indicator
K4-1 US	Universal clamp for up to 1.05" dia jackshafts
K4-H	Universal clamp for hexshafts 3/8" to 5/8"
KH-AF	Crankarm for up to 3/4" round shaft
KH-AF-1	Crankarm for up to 1.05" jackshaft
KH-AFV	V-bolt kit for KH-AF and KH-AF-1
Tool-06	8mm and 10 mm wrench
ZG-HTR	Thermostat/Heater Kit
ZDB-AF2 US	Angle of rotation limiter
ZG-100	Universal mounting bracket
ZG-101	Universal mounting bracket
ZG-102	Multiple actuator mounting bracket
ZG-106	Mounting bracket for Honeywell® Mod IV replacement or new crankarm type installations
ZG-107	Mounting bracket for Honeywell® Mod III or Johnson® Series 100 replacement or new crankarm type installations
ZG-108	Mounting bracket for Barber Colman® MA 3../4., Honeywell® Mod III or IV or Johnson® Series 100 replacement or new crankarm type installations
ZG-AF US	Crankarm adaptor kit for AF/NF
ZG-AF108	Crankarm adaptor kit for AF/NF
ZS-100	Weather shield (metal)
ZS-150	Weather shield (polycarbonate)
ZS-260	Explosion-proof housing
ZS-300	NEMA 4X housing

Note: When using NF24 (-S, -S2) US actuators, only use accessories listed on this page. For Actuator Wiring Information and Diagrams, Please See Belimo Wiring Guide (pg 349).

### Typical Specification

On/Off spring return damper actuators shall be direct coupled type which require no crankarm and linkage and be capable of direct mounting to a jackshaft up to a 1.05" diameter. The actuators must be designed so that they may be used for either clockwise or counterclockwise fail-safe operation. Actuators shall be protected from overload at all angles of rotation. If required, 1 or 2 SPDT auxiliary switch shall be provided having the capability of being adjustable. Actuators with auxiliary switches must be constructed to meet the requirements for Double Insulation so an electrical ground is not required to meet agency listings. Actuators shall be UL Approved and CSA certified, have a 5 year warranty, and be manufactured under ISO 9001 International Quality Control Standards. Actuators shall be as manufactured by Belimo.

### Wiring Diagrams

#### ✂ INSTALLATION NOTES

- 1 Provide overload protection and disconnect as required.
- 2 **CAUTION Equipment damage!**  
Actuators may be connected in parallel. Power consumption and input impedance must be observed.
- 3 Actuators may also be powered by 24 VDC.
- 4 For end position indication, interlock control, fan startup, etc., NF24-S US incorporates a built-in auxiliary switch: 1 x SPDT, 7A (1.5A) @250 VAC, UL Approved, adjustable 5° to 85°. NF24-S2 US incorporates two built-in auxiliary switches: 2 x SPDT, 7A (2.5A) @250 VAC, UL Approved, one switch is fixed at +5°, one is adjustable 25° to 85°.

#### 📄 APPLICATION NOTES

- ◆ Meets cULus requirements without the need of an electrical ground connection.

#### ⚠ WARNING Live Electrical Components!

During installation, testing, servicing and troubleshooting of this product, it may be necessary to work with live electrical components. Have a qualified licensed electrician or other individual who has been properly trained in handling live electrical components perform these tasks. Failure to follow all electrical safety precautions when exposed to live electrical components could result in death or serious injury.

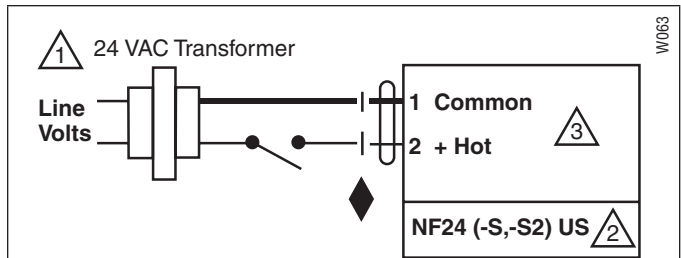

On/Off wiring for NF24 US

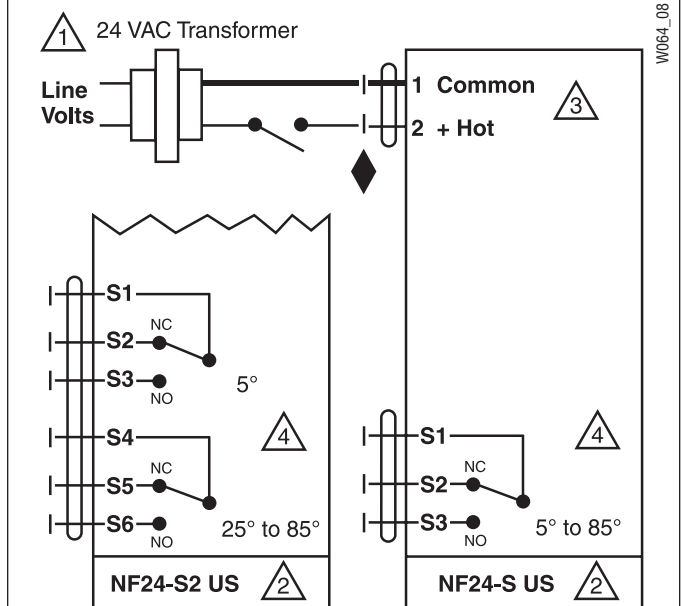

On/Off wiring for NF24-S US

# NF120(-S) US

On/Off, Spring Return Fail-Safe, 120 VAC



Technical Data		NF120(-S) US
Power supply		120 VAC $\pm$ 10% 50/60 Hz
Power consumption	running	7 W
	holding	4 W
Transformer sizing		9.5 VA
Electrical connection		3 ft, 18 GA appliance cable 1/2" conduit connector
Overload protection		Electronic throughout 0 to 95° rotation
Electrical protection		Auxiliary switches are double insulated
Angle of rotation		95°, adjustable 30 to 95° w/ accessories
Torque		60 in-lb [7 Nm] constant torque
Direction of rotation		reversible with CW/CCW mounting
Position indication		visual indicator, 0° to 95° (0° is spring return position)
Running time (nominal)	motor	< 75 sec
	spring	< 60 sec
Humidity		5 to 95% RH non-condensing
Ambient temperature		-22°F to 122°F [-30°C to 50°C]
Storage temperature		-40°F to 176°F [-40°C to 80°C]
Housing		NEMA type 2 / IP54
Housing material		zinc coated steel
Agency listings		cULus acc. to UL 873 and CAN/CSA C22.2 No. 24-93
Noise level		max. 45 dB (A)
Servicing		maintenance free
Quality standard		ISO 9001
Weight		7.3 lbs (3.3 kg)
<b>NF120-S</b>		
Auxiliary switches		1 x SPDT 7A (2.5A) @ 250 VAC, UL Approved, adjustable 5° to 85°

**Torque min. 60 in-lb, for control of air dampers**

## Application

For On/Off, fail-safe control of dampers in HVAC systems. Actuator sizing should be done in accordance with the damper manufacturer's specifications. Control is On/Off from an auxiliary contact, or a manual switch.

The actuator is mounted directly to a damper shaft up to 1.05" in diameter by means of its universal clamp. A crank arm and several mounting brackets are available for applications where the actuator cannot be direct coupled to the damper shaft.

## Operation

The NF series actuators provide true spring return operation for reliable fail-safe application and positive close off on air tight dampers. The spring return system provides constant torque to the damper with, and without, power applied to the actuator.

The NF series provides 95° of rotation and is provided with a graduated position indicator showing 0° to 95°.

The actuator may be stalled anywhere in its normal rotation without the need of mechanical end switches.

The NF120-S US versions are provided with 1 built-in auxiliary switch. This SPDT switch is provided for safety interfacing or signaling, for example, for fan start-up. The switching function is adjustable between 5° and 85°.

## Dimensions (Inches [mm])

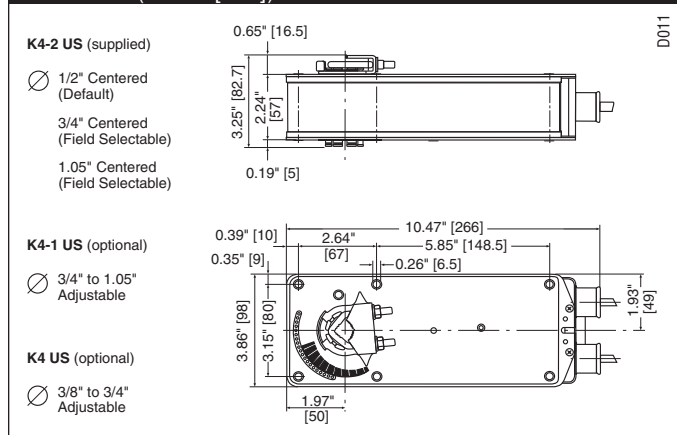

K20901 - 01/09 - Subject to change. © Belimo Aircontrols (USA), Inc.

### Accessories

AV 10-18	Shaft extension
IND-AF2	Damper position indicator
K4-1 US	Universal clamp for up to 1.05" dia jackshafts
K4-H	Universal clamp for hexshafts 3/8" to 5/8"
KH-AF	Crankarm for up to 3/4" round shaft
KH-AF-1	Crankarm for up to 1.05" jackshaft
KH-AFV	V-bolt kit for KH-AF and KH-AF-1
Tool-06	8mm and 10 mm wrench
ZG-HTR	Thermostat/Heater Kit
ZDB-AF2 US	Angle of rotation limiter
ZG-100	Universal mounting bracket
ZG-101	Universal mounting bracket
ZG-102	Multiple actuator mounting bracket
ZG-106	Mounting bracket for Honeywell® Mod IV replacement or new crankarm type installations
ZG-107	Mounting bracket for Honeywell® Mod III or Johnson® Series 100 replacement or new crankarm type installations
ZG-108	Mounting bracket for Barber Colman® MA 3..4..., Honeywell® Mod III or IV or Johnson® Series 100 replacement or new crankarm type installations
ZG-AF US	Crankarm adaptor kit for AF/NF
ZG-AF108	Crankarm adaptor kit for AF/NF
ZS-100	Weather shield (metal)
ZS-150	Weather shield (polycarbonate)
ZS-260	Explosion-proof housing
ZS-300	NEMA 4X housing

**NOTE:** When using NF120 US and NF120-S actuators, only use accessories listed on this page. For Actuator Wiring Information and Diagrams, Please See Belimo Wiring Guide (pg 349).

### Typical Specification

On/Off spring return damper actuators shall be direct coupled type which require no crankarm and linkage and be capable of direct mounting to a jackshaft up to a 1.05" diameter. The actuators must be designed so that they may be used for either clockwise or counterclockwise fail-safe operation. Actuators shall be protected from overload at all angles of rotation. If required, 1 SPDT auxiliary switch shall be provided having the capability of being adjustable. Actuators with auxiliary switches must be constructed to meet the requirements for Double Insulation so an electrical ground is not required to meet agency listings. Actuators shall be UL Approved and CSA certified, have a 5 year warranty, and be manufactured under ISO 9001 International Quality Control Standards. Actuators shall be as manufactured by Belimo.

### Wiring Diagrams

#### ✂ INSTALLATION NOTES

- 1 Provide overload protection and disconnect as required.
- 2 **CAUTION Equipment damage!**  
Actuators may be connected in parallel. Power consumption and input impedance must be observed.
- 3 No ground connection is required.
- 4 For end position indication, interlock control, fan startup, etc., NF-20-S US incorporates one built-in auxiliary switch: 1 x SPDT, 7A (2.5A) @250 VAC, UL Approved, adjustable 5° to 85°.

#### 📄 APPLICATION NOTES

- ◆ Meets cULus requirements without the need of an electrical ground connection.

#### ⚠ WARNING Live Electrical Components!

During installation, testing, servicing and troubleshooting of this product, it may be necessary to work with live electrical components. Have a qualified licensed electrician or other individual who has been properly trained in handling live electrical components perform these tasks. Failure to follow all electrical safety precautions when exposed to live electrical components could result in death or serious injury.

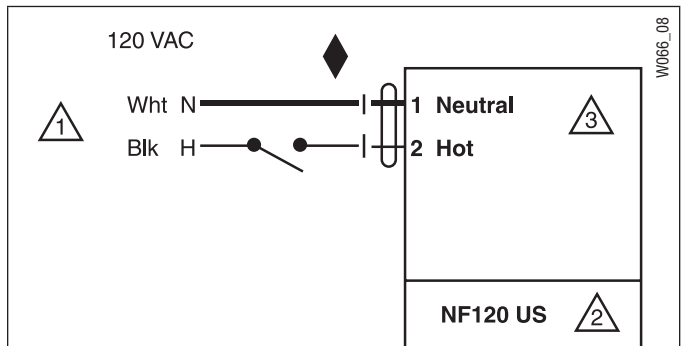

On/Off wiring for NF120 US

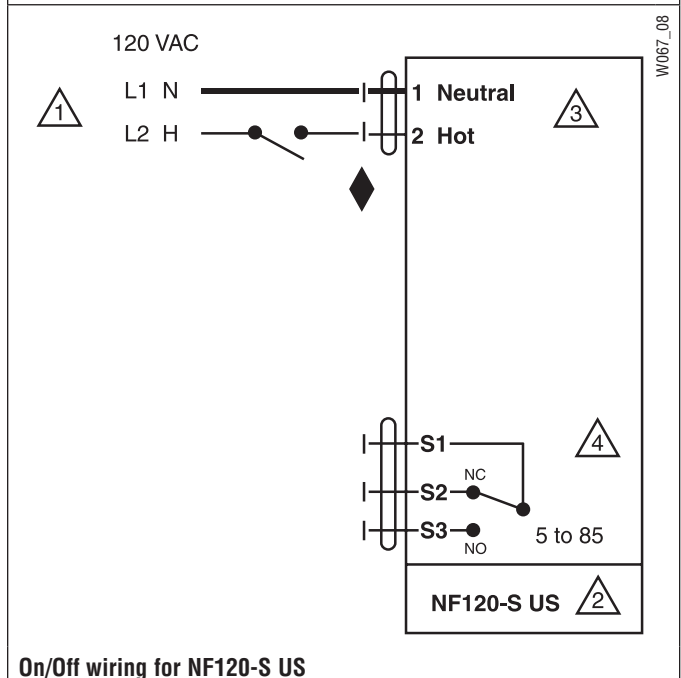

On/Off wiring for NF120-S US



# NF24-SR(-S) US

Proportional Damper Actuator, Spring Return Fail-Safe, 24 V for 2 to 10 VDC, or 4 to 20 mA Control Signal  
Output Signal of 2 to 10 VDC for Position Indication



Technical Data		NF24-SR US
Power supply		24 VAC $\pm$ 20% 50/60 Hz 24 VDC $\pm$ 10%
Power consumption	running	3 W
	holding	1 W
Transformer sizing		6 VA (class 2 power source)
Electrical connection		3 ft, 18 GA appliance cable 1/2" conduit connector
Overload protection		Electronic throughout 0 to 95° rotation
Operating range Y		2 to 10 VDC, 4 to 20mA
Input impedance		100 k $\Omega$ (0.1 mA), 500 $\Omega$
Feedback output U		2 to 10 VDC (max. 0.5 mA) for 95°
Angle of rotation		95°, adjustable 30° to 95° w/accessory
Torque		60 in-lb [7 Nm] constant torque
Direction of rotation	spring	reversible with cw/ccw mounting
	motor	reversible with built-in switch
Position indication		visual indicator, 0° to 95° (0° is spring return position)
Running time (nominal)	motor	150 sec constant, independent of load
	spring	< 60 sec
Humidity		5 to 95% RH non-condensing
Ambient temperature		-22°F to +122°F [-30°C to +50°C]
Storage temperature		-40°F to +176°F [-40°C to +80°C]
Housing		NEMA type 2 / IP54
Housing material		zinc coated metal
Agency listings		UL 873 listed, CSA C22.2 No.24 certified
Noise level		max. 45 dB (A)
Servicing		maintenance free
Quality standard		ISO 9001
Weight		6.0 lbs (2.7 kg)

NF24-SR-S	
Auxiliary switches	1 x SPDT 7A (2.5A) @ 250 VAC, UL Approved adjustable 5° to 85°

**Torque min. 60 in-lb, for control of air dampers**

## Application

For proportional modulation of dampers in HVAC systems. Actuator sizing should be done in accordance with the damper manufacturer's specifications.

The actuator is mounted directly to a damper shaft up to 1.05" in diameter by means of its universal clamp. A crank arm and several mounting brackets are available for applications where the actuator cannot be direct coupled to the damper shaft.

The actuator operates in response to a 2 to 10 VDC, or with the addition of a 500 $\Omega$  resistor, a 4 to 20 mA control input from an electronic controller or positioner. A 2 to 10 VDC feedback signal is provided for position indication or master-slave applications.

## Operation

The NF series actuators provide true spring return operation for reliable fail-safe application and positive close-off on air tight dampers. The spring return system provides constant torque to the damper with, and without, power applied to the actuator.

The NF series provides 95° of rotation and is provided with a graduated position indicator showing 0° to 95°.

The NF24-SR US uses a brushless DC motor which is controlled by an Application Specific Integrated Circuit (ASIC) and a microprocessor. The microprocessor provides the intelligence to the ASIC to provide a constant rotation rate and to know the actuator's exact fail-safe position. The ASIC monitors and controls the brushless DC motor's rotation and provides a digital rotation sensing function to prevent damage to the actuator in a stall condition. The actuator may be stalled anywhere in its normal rotation without the need of mechanical end switches.

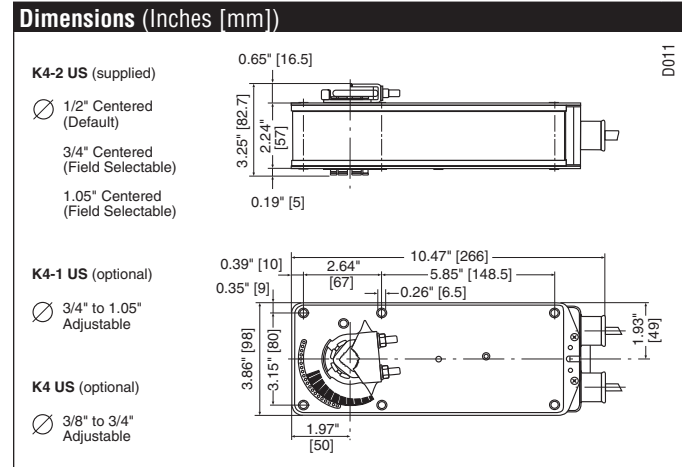

K20901 - 01/09 - Subject to change. © Belimo Aircontrols (USA), Inc.

Accessories	
AV 10-18	Shaft extension
IND-AF2	Damper position indicator
K4-1 US	Universal clamp for up to 1.05" dia jackshafts
K4-H	Universal clamp for hexshafts 3/8" to 5/8"
KH-AF	Crankarm for up to 3/4" round shaft
KH-AF-1	Crankarm for up to 1.05" jackshaft
KH-AFV	V-bolt kit for KH-AF and KH-AF-1
PTA-250	Pulse width modulation interface
Tool-06	8mm and 10 mm wrench
SGA24	Min. and/or man. positioner in NEMA 4 housing
SGF24	Min. and/or man. positioner for flush panel mounting
ZG-R01	500Ω resistor for 4 to 20mA control signal
ZG-HTR	Thermostat/Heater Kit
ZDB-AF2 US	Angle of rotation limiter
ZG-100	Universal mounting bracket
ZG-101	Universal mounting bracket
ZG-102	Multiple actuator mounting bracket
ZG-106	Mounting bracket for Honeywell® Mod IV replacement or new crankarm type installations
ZG-107	Mounting bracket for Honeywell® Mod III or Johnson® Series 100 replacement or new crankarm type installations
ZG-108	Mounting bracket for Barber Colman® MA 3..4..., Honeywell® Mod III or IV or Johnson® Series 100 replacement or new crankarm type installations
ZG-AF US	Crankarm adaptor kit for AF/NF
ZG-AF108	Crankarm adaptor kit for AF/NF
ZS-100	Weather shield (metal)
ZS-150	Weather shield (polycarbonate)
ZS-260	Explosion-proof housing
ZS-300	NEMA 4X housing

**NOTE:** When using NF24-SR US actuators, only use accessories listed on this page. For Actuator Wiring Information and Diagrams, Please See Belimo Wiring Guide (pg 349).

### Typical Specification

Spring return control damper actuators shall be direct coupled type which require no crankarm and linkage and be capable of direct mounting to a jackshaft up to a 1.05" diameter. The actuator must provide proportional damper control in response to a 2 to 10 VDC or, with the addition of a 500Ω resistor, a 4 to 20 mA control input from an electronic controller or positioner. The actuators must be designed so that they may be used for either clockwise or counterclockwise fail-safe operation. Actuators shall use a brushless DC motor controlled by a microprocessor and be protected from overload at all angles of rotation. Run time shall be constant, and independent of torque. A 2 to 10 VDC feedback signal shall be provided for position feedback or master-slave applications. Actuators shall be UL Approved and CSA certified, have a 5 year warranty, and be manufactured under ISO 9001 International Quality Control Standards. Actuators shall be as manufactured by Belimo.

### Wiring Diagrams

#### INSTALLATION NOTES

- 1 Provide overload protection and disconnect as required.
- 2 **CAUTION Equipment damage!**  
Actuators may be connected in parallel. Power consumption and input impedance must be observed.
- 2 Up to 4 actuators may be connected in parallel. With 4 actuators wired to one 500 Ω resistor. Power consumption must be observed.
- 3 Actuator may also be powered by 24 VDC.
- 5 Only connect common to neg. (-) leg of control circuits

6 For end position indication, interlock control, fan startup, etc., NF24-SR US incorporates a built-in auxiliary switch: 1 x SPDT, 7A (1.5A) @250 VAC, UL Approved, adjustable 5° to 85°.

#### APPLICATION NOTES

The ZG-R01 500 Ω resistor converts the 4 to 20 mA control signal to 2 to 10 VDC, up to 2 actuators may be connected in parallel.

**WARNING Live Electrical Components!**  
During installation, testing, servicing and troubleshooting of this product, it may be necessary to work with live electrical components. Have a qualified licensed electrician or other individual who has been properly trained in handling live electrical components perform these tasks. Failure to follow all electrical safety precautions when exposed to live electrical components could result in death or serious injury.

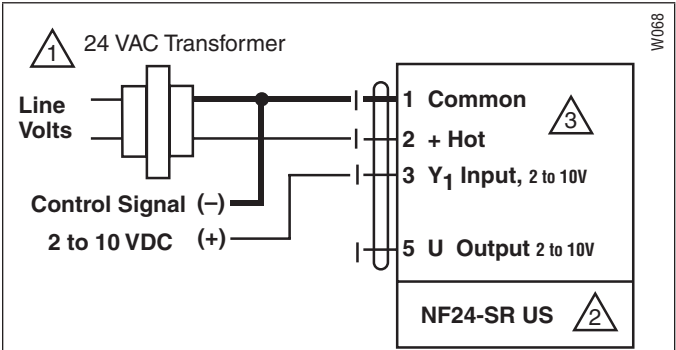

2 to 10 VDC control of NF24-SR US

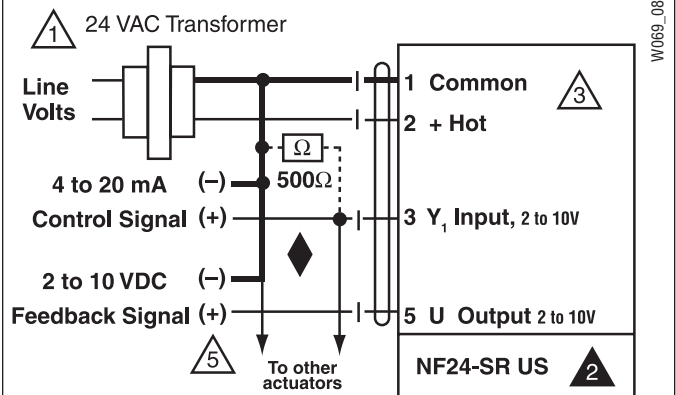

4 to 20 mA control of NF24-SR US with 2 to 10 VDC feedback output

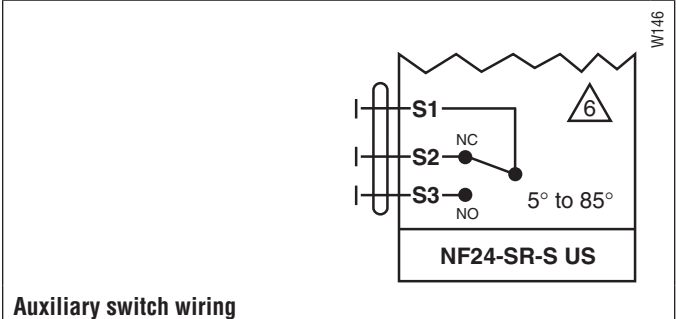

Auxiliary switch wiring





Technical Data		NF24-MFT US
Power supply		24 VAC, ± 20%, 50/60 Hz 24 VDC, ±10%
Power consumption	running holding	3 W 1.8 W
Transformer sizing		6 VA (Class 2 power source)
Electrical connection		3 ft, 18 GA, appliance cable, 1/2" conduit connector
Overload protection		electronic throughout 0 to 95° rotation
Operating range Y*		2 to 10 VDC 4 to 20 mA (w/500 Ω, 1/4 Ω resistor) ZG-R01
Input impedance		100 kΩ for 2 to 10 VDC (0.1 mA) 500 Ω for 4 to 20 mA 1500 Ω for PWM, Floating point and On/Off control
Feedback output U*		2 to 10 VDC, 0.5 mA max
Torque		min 60 in-lb (8 Nm)
Direction of rotation*	spring motor	reversible with cw/ccw mounting reversible with built-in switch
Mech. angle of rotation*		95°, adjustable 30° to 90° w/ZDB-AF2 US
Running time	motor* spring	150 sec constant <60 sec
Angle of Rotation Adaptation*		Off (Default)
Override control*		Min. (Min Position) = 0% - ZS (Mid. Position) = 50% - Max. (Max. Position) = 100%
Position indication		visual indicator, 0° to 95°
Humidity		5 to 95% RH, non-condensing
Ambient temperature		-22 to 122° F (-30 to 50° C)
Storage temperature		-40 to 176° F (-40 to 80° C)
Housing		NEMA 2, IP54
Housing material		zinc coated metal
Noise level		less than 45 dB (A)
Agency listings		UL 873 listed, CSA C22.2 No. 24 certified
Quality standard		ISO 9001
Servicing		maintenance free
Weight		6.0 lbs. (2.7 kg)

\* Variable when configured with MFT options

- Torque min. 60 in-lb
- Control 2 to 10 VDC (DEFAULT)
- Feedback 2 to 10 VDC (DEFAULT)

## Application

For proportional modulation of dampers and control valves in HVAC systems. The NF24-MFT US provides mechanical spring return operation for reliable fail-safe application.

## Default/Configuration

Default parameters for 2 to 10 VDC applications of the NF24-MFT US actuator are assigned during manufacturing. If required, custom versions of the actuator can be ordered. The parameters noted in the Technical Data table are variable.

These parameters can be changed by three means:

- Pre-set configurations from Belimo
- Custom configurations from Belimo
- Configurations set by the customer using the MFT PC tool software application.

## Operation

The NF24-MFT US actuator provides 95° of rotation and is provided with a graduated position indicator showing 0° to 95°. The actuator will synchronize the 0° mechanical stop or the damper or valves mechanical stop and use this point for its zero position during normal control operations.

The actuator uses a brushless DC motor which is controlled by an Application Specific Integrated Circuit (ASIC) and a microprocessor. The microprocessor provides the intelligence to the ASIC to provide a constant rotation rate and to know the actuator's exact position. The ASIC monitors and controls the brushless DC motor's rotation and provides a Digital Rotation Sensing (DRS) function to prevent damage to the actuator in a stall condition. The position feedback signal is generated with out the need for mechanical feedback potentiometers using DRS. The actuator may be stalled anywhere in its normal rotation without the need of mechanical end switches.

The NF24-MFT US is mounted directly to control shafts up to 1.05" diameter by means of its universal clamp and anti-rotation bracket. A crankarm and several mounting brackets are available for damper applications where the actuator cannot be direct coupled to the damper shaft. The spring return system provides minimum specified torque to the application during a power interruption. The NF24-MFT US actuator is shipped in the zero position, compression against seats or gaskets for tight shut-off is accomplished manually.

**NOTE:** Please See Documentation on Multi-Function Technology pg 287.

## Dimensions (Inches [mm])

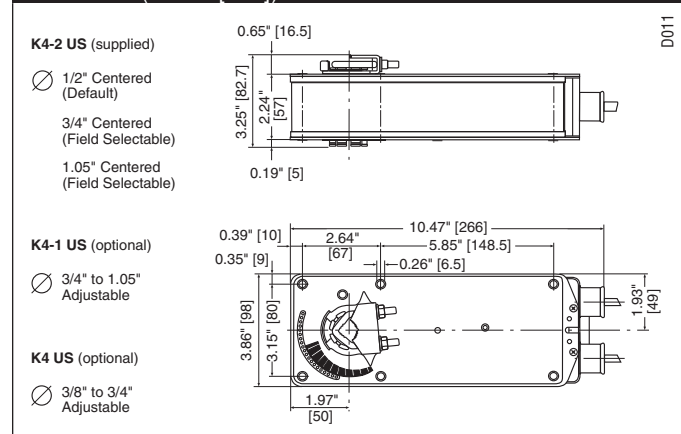

K20901 - 01/09 - Subject to change. © Belimo Aircontrols (USA), Inc.

### Wiring Diagrams

#### ✂ INSTALLATION NOTES

- 1 Provide overload protection and disconnect as required.
- 2 **CAUTION Equipment damage!**  
Actuators may be connected in parallel if not mechanically mounted to the same shaft. Power consumption and input impedance must be observed.
- 3 Actuators may also be powered by 24 VDC.

#### 📄 APPLICATION NOTES

- ◆ The ZG-R01 500 Ω resistor may be used.

#### ⚠ WARNING Live Electrical Components!

During installation, testing, servicing and troubleshooting of this product, it may be necessary to work with live electrical components. Have a qualified licensed electrician or other individual who has been properly trained in handling live electrical components perform these tasks. Failure to follow all electrical safety precautions when exposed to live electrical components could result in death or serious injury.

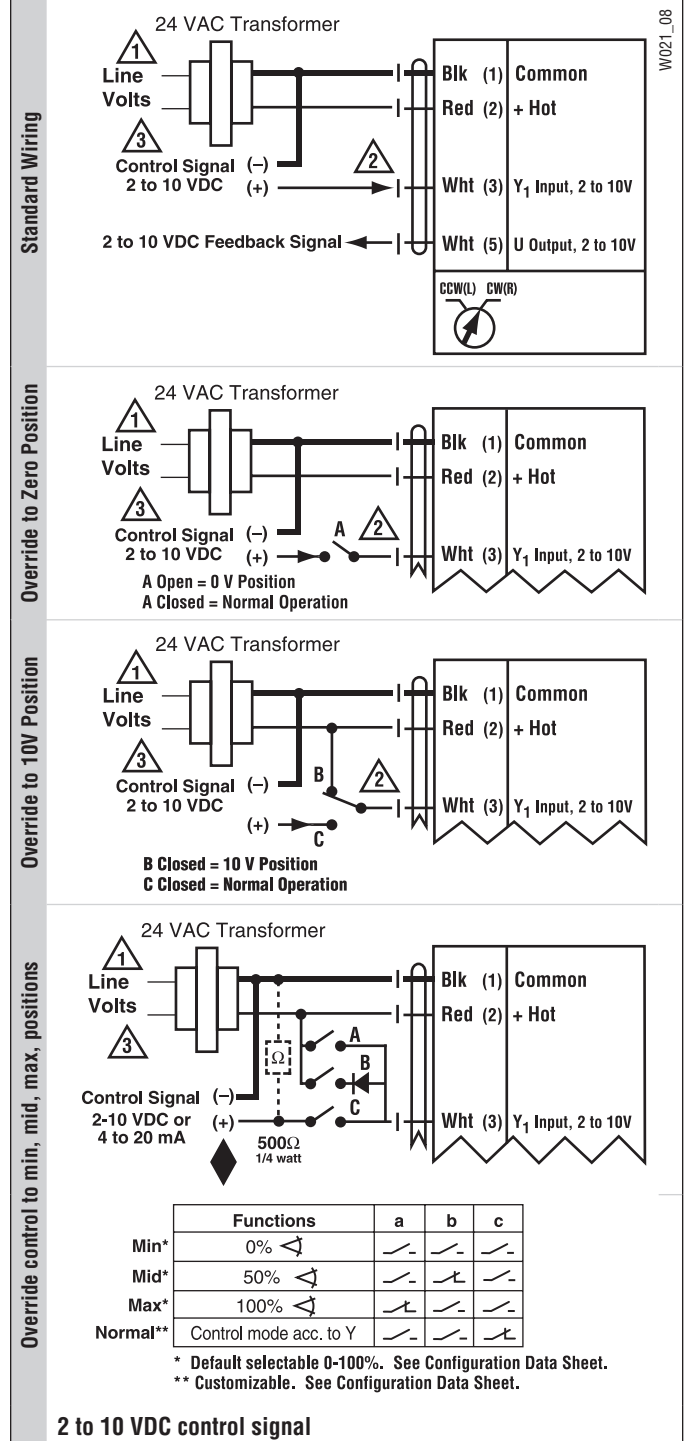
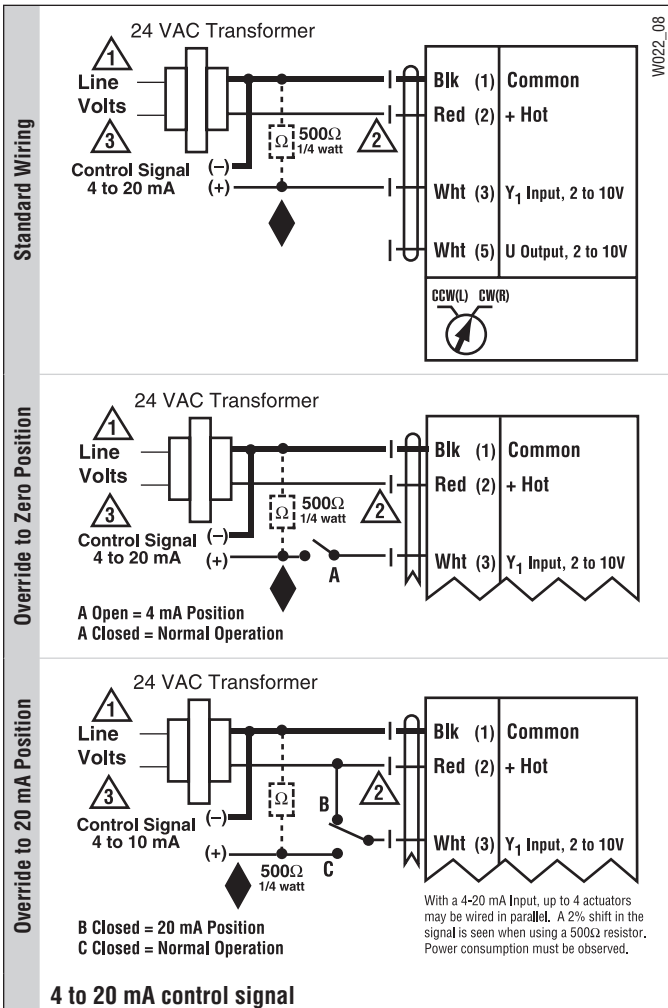

2 to 10 VDC control signal

### Quick-Mount Visual Instructions

1. Rotate the damper to its failsafe position.  
If the shaft rotates counterclockwise, mount the "CCW" side of the actuator out.  
If it rotates clockwise, mount the actuator with the "CW" side out.
2. If the universal clamp is not on the correct side of the actuator, move it to the correct side for ease of installation.
3. Slide the actuator onto the shaft and tighten the nuts on the V-bolt with a 10mm wrench to 6-8 ft-lb of torque.
4. Slide the anti-rotation strap under the actuator so that it engages the slot at the base of the actuator. Secure the strap to the duct work with #8 self-tapping screws.

**NOTE:** Read the "Standard Mounting" instructions, on the next page, for more detailed information.

### Dimensions (Inches [mm])

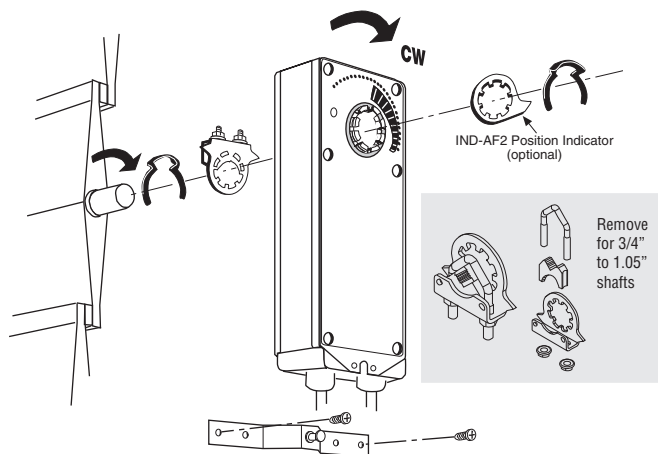
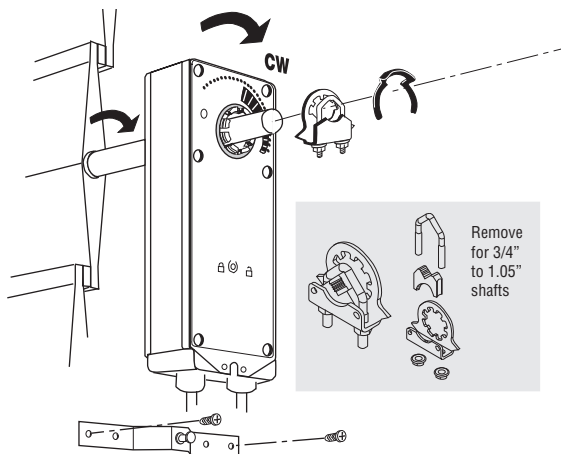
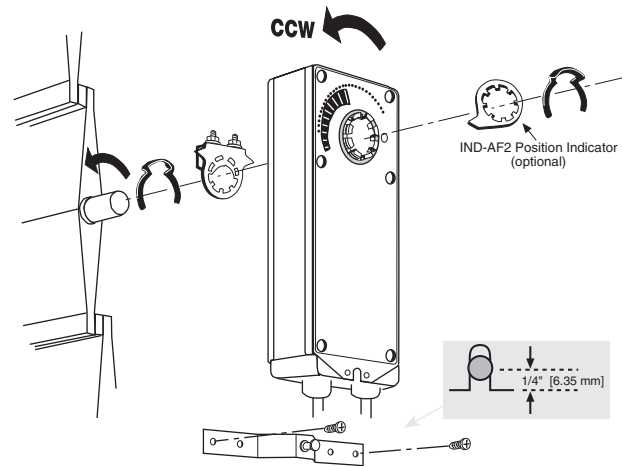
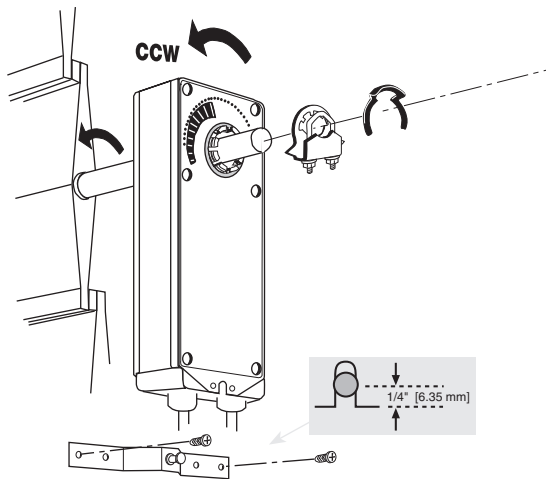
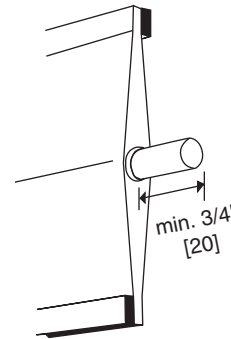
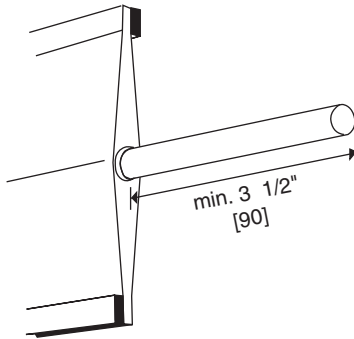

K20901 - 01/09 - Subject to change. © Belimo Aircontrols (USA), Inc.

### Determining Torque Loading and Actuator Sizing

Damper torque loadings, used in selecting the correct size actuator, should be provided by the damper manufacturer. If this information is not available, the following general selection guidelines can be used.

Damper Type	Torque Loading
Opposed blade, without edge seals, for non-tight close-off applications	3 in-lb/sq. ft.
Parallel blade, without edge seals, for non-tight close-off applications	4 in-lb/sq. ft.
Opposed blade, with edge seals, for tight close-off applications	5 in-lb/sq. ft.
Parallel blade, with edge seals, for tight close-off applications	7 in-lb/sq. ft.

The above torque loadings will work for most applications under 2 in. w.g. static pressure or 1000 FPM face velocity. For applications between this criteria and 3 in. w.g. or 2500 FPM, the torque loading should be increased by a multiplier of 1.5. If the application calls for higher criteria up to 4 in. w.g. or 3000 FPM, use a multiplier of 2.0.

**Torque Loading Chart**

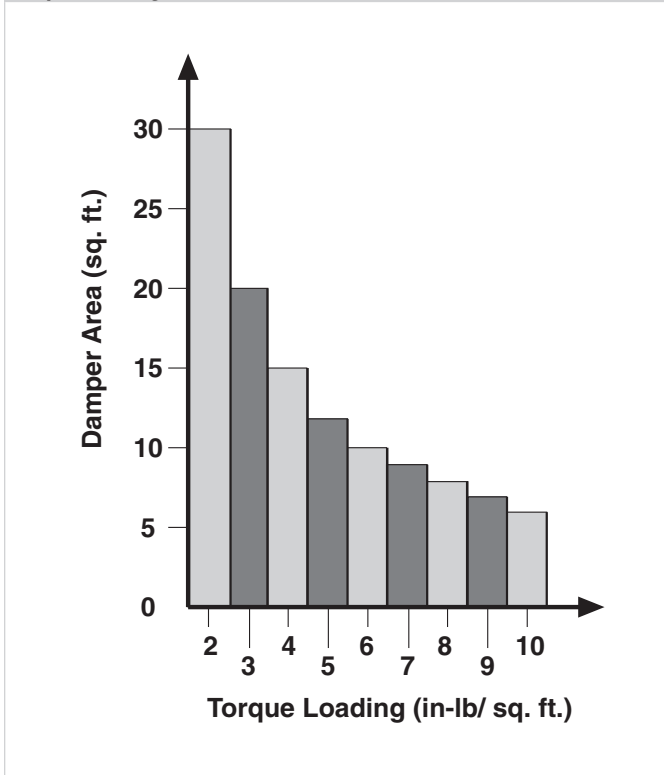

### General Information

Belimo actuators should be mounted indoors in a dry, relatively clean environment free from corrosive fumes. If the actuator is to be mounted outdoors, a protective enclosure must be used to shield the actuator. For new construction work, order dampers with extended shafts. Instruct the installing contractor to allow space for mounting and service of the Belimo actuator on the shaft. The damper shaft must extend at least 3 1/2" from the duct. If the shaft extends less than 3 1/2" or if an obstruction blocks access, the shaft can be extended with the AV 10-18 shaft extension or the actuator may be mounted in its short shaft configuration.

### Mechanical Operation

The actuator is mounted directly to a damper shaft up to 1.05" in diameter by means of its universal clamp. A crank arm and several mounting brackets are available for applications where the actuator cannot be direct coupled to the damper shaft.

The NF series actuators provide true spring return operation for reliable fail-safe application and positive close-off on air tight dampers. The spring return system provides consistent torque to the damper with, and without, power applied to the actuator.

The NF series provides 95° of rotation and is provided with a graduated position indicator showing 0° to 95°.

The NF...-S versions are provided with 1 built-in auxiliary switch. This SPDT switch is provided for safety interfacing or signaling, for example, for fan start-up. The switching function is adjustable between 5° and 85° (NF24-S2, with 2 built-in switches, adjustable between +25° and +85°).

### Standard Mounting

1. See **Figure B**. Manually move the damper to the fail-safe position (a) (usually closed). If the shaft rotated counterclockwise (↺), this is a CCW installation. If the shaft rotated clockwise (↻), this is a CW installation. In a CCW installation, the actuator side marked "CCW" faces out, while in a CW installation, the side marked "CW" faces out. All other steps are identical.
2. The actuator is usually shipped with the universal clamp mounted to the "CCW" side of the actuator. To test for adequate shaft length, slide the actuator over the shaft with the side marked "CCW" (or the "CW" side if this is the side with the clamp). If the shaft extends at least 1/8" through the clamp, mount the actuator as follows. If not, go to the Short Shaft Installation section.
3. If the clamp is not on the correct side as determined in step #1, re-mount the clamp as follows. If it is on the correct side, proceed to step #5. Look at the universal clamp. If you are mounting the actuator with the "CCW" side out, position the clamp so that the pointer section of the tab is pointing to 0° (see **Figure C**) and the spline pattern of the clamp mates with spline of the actuator. Slip the clamp over the spline. (Use the same procedure if the "CW" side is out.) If your application requires a mechanical minimum position, read the Rotation Limitation section.
4. Lock the clamp to the actuator using the retaining clip.
5. Verify that the damper is still in its full fail-safe position (a).
6. Mount the spring return actuator to the shaft. Tighten the universal clamp, finger tight only.
7. Mount the anti-rotation strap at the base of the actuator. Slip the stop of the anti-rotation strap in the slot of the base of the actuator. The stud should be centered approximately 1/4" from the end of the slot. Do not tighten the screws.
8. Remove the screw from one end of the mounting bracket and pivot it away from the actuator.
9. Loosen the universal clamp and, making sure not to move the damper shaft, rotate the actuator approximately 5° in the direction which would open the damper.
10. Tighten the universal clamp to the shaft.
11. Rotate the actuator to apply pressure to the damper seals (b) and re-engage the anti-rotation strap (c).
12. Tighten all fasteners.

### Short Shaft Installation

If the shaft extends at least 3/4" from the duct, follow these steps:

1. Move damper blades to the fail-safe position (a).
2. Determine the best orientation for the universal clamp on the back of the actuator. The best location would be where you have the easiest access to the V bolt nuts on the clamp.
3. Engage the clamp to the actuator as close as possible to the determined location.
4. Lock the clamp to the actuator using the retainer clip.
5. Mount the spring return actuator to the shaft. Tighten the universal clamp, finger tight only.
6. Mount the anti-rotation strap at the base of the actuator. Do not tighten the screws.
7. Remove the screw from one end of the mounting bracket and pivot it away from the actuator.
8. Loosen the universal clamp and, making sure not to move the damper shaft, rotate the actuator approximately 5° in the direction which would open the damper.
9. Verify that the damper is still in its full fail-safe position.
10. Tighten the universal clamp to the shaft.
11. Rotate the actuator to apply pressure to the damper seals (b) and re-engage the anti-rotation strap (c).
12. Tighten all fasteners.

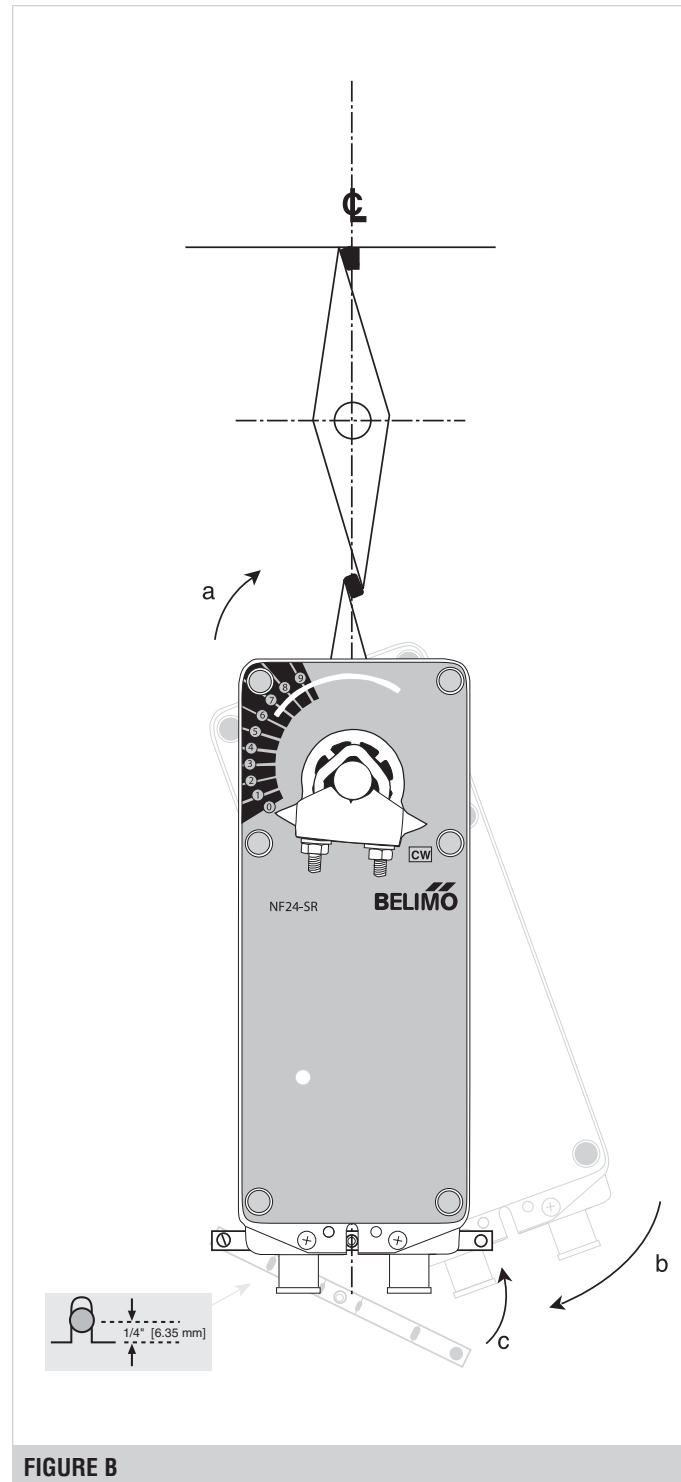

**FIGURE B**

**Rotation Limitation**

The angle of rotation limiter, ZDB-AF2 US, is used in conjunction with the tab on the universal clamp or IND-AF2 position indicator which comes with the ZDB-AF2 US. In order to function properly, the clamp or indicator must be mounted correctly.

See **Figure A**.

The ZDB-AF2 US may not work in certain mounting orientations using the ZG-106 or ZG-107 mounting brackets. It will not work with the ZG-108 mounting bracket. Limiting the damper rotation must be accomplished by adjusting the crank arm linkage.

The ZDB-AF2 US may be used to control the rotational output of the NF series actuator where a damper has a designed rotation less than 90°. An example would be a 45° or 60° rotating damper.

**Damper Rotation Limiting**

1. Determine the amount of damper rotation required.
2. Locate the Angle of Rotation Limiter (ZDB-AF2 US) on the actuator so that its edge lines up with the degree graduation on the actuator face which corresponds with the required rotation. See **Figure C**.
3. Find the appropriate cross-hair location through the slot of the limiter. This is the screw mounting location.
4. Pierce through the label material to allow easy fastening of the retaining screw.
5. Position the limiter back to the desired position, making sure the locating "teeth" on the limiter are engaged into the locating holes on the actuator.
6. Fasten the limiter to the actuator using the self tapping screw provided.
7. Test the damper rotation before applying power and if required, a control signal. Re-adjust if necessary.

**Auxiliary Switches**

The NF series actuators may be ordered with 1 built-in SPDT auxiliary switch used for safety interfacing or signalling, for example, for fan start-up. The switch position is adjustable between 5° and 85° of rotation. The crank, supplied with the actuator, or a 3mm allen wrench (NF24-S2, with 2 built-in switches, adjustable between +25° and +85°) is used to adjust the switching position.

See **Figure D**.

1. The actuator must be in its fail-safe position.
2. Insert the crank into the hexagon shaped hole located in the center of the adjustable switch pointer.
3. Rotate the crank until the switch pointer is at the desired switch point in degrees as shown.

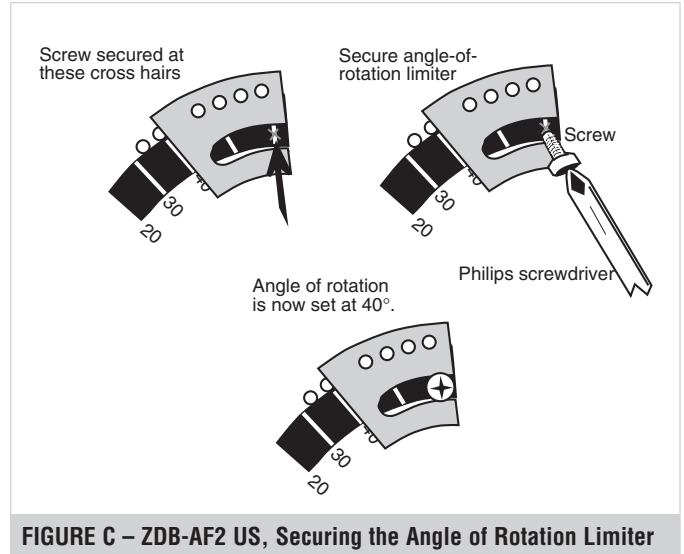

**FIGURE C – ZDB-AF2 US, Securing the Angle of Rotation Limiter**

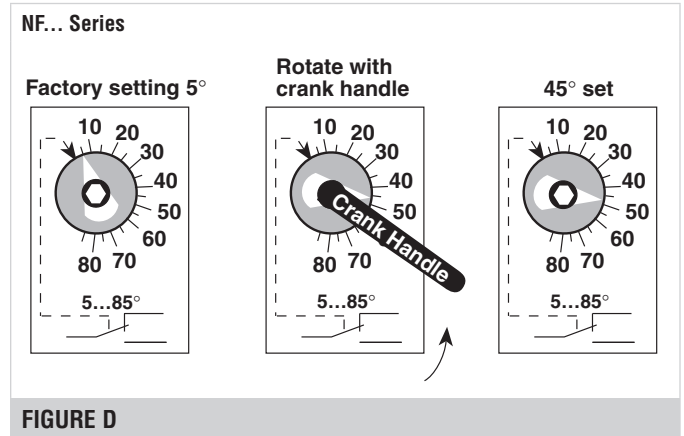

**FIGURE D**





## KH-AF Crankarm Including Retaining Ring

**CAUTION:** The retaining clip supplied with the clamp is **not** used to mount the KH-AF crankarm.

The KH-AF (-1) crankarm is used in non-direct coupled mounting applications.

TWO SIZES ARE AVAILABLE:

**KH-AF** For round shafts up to 3/4" or square shafts up to 5/8"

**KH-AF-1** For jackshafts up to 1.05"

### Dimensions (Inches [mm])

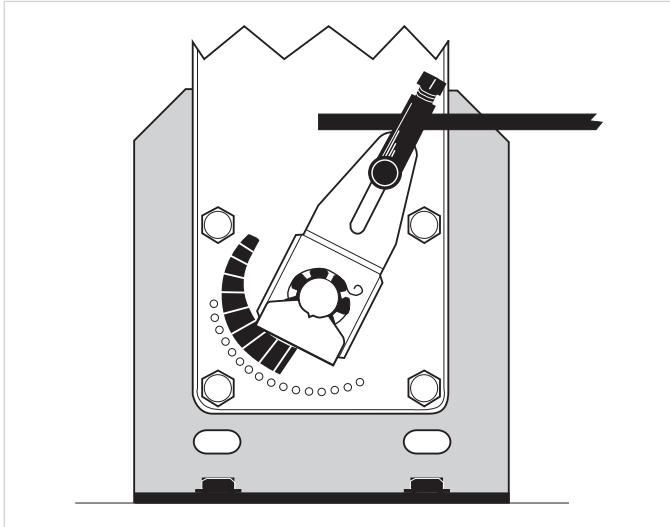
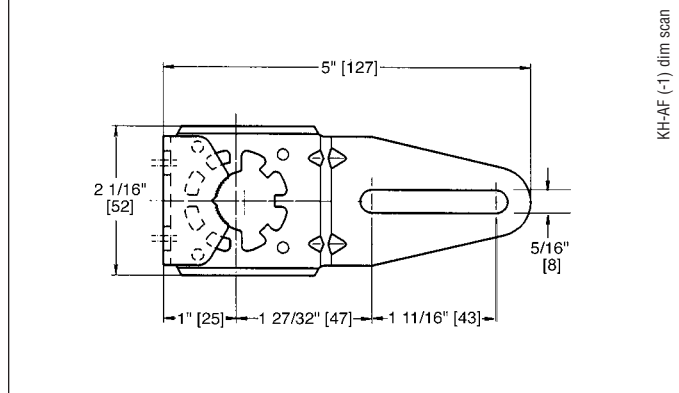

**KH-AF non-direct mounting with ZG-108 mounting bracket**

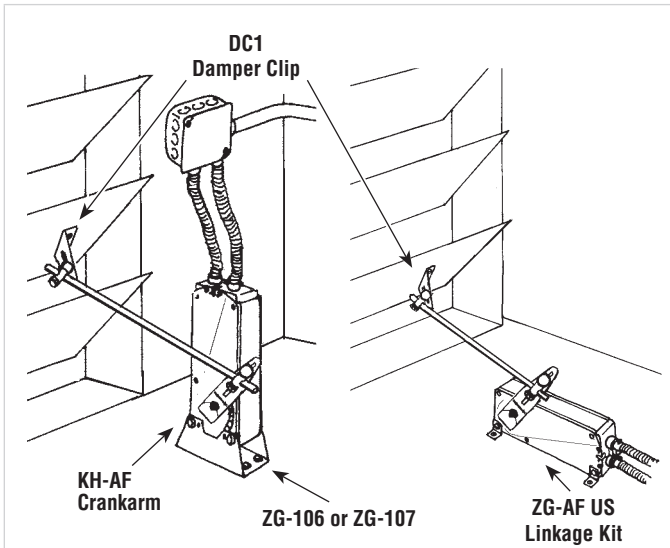

**Non-direct mounting using various accessories**

K20901 - 01/09 - Subject to change. © Belimo Aircontrols (USA), Inc.

### Initialization of the NF14-SR US and NF24-MFT US

When power is initially applied, the microprocessor recognizes that the actuator is at full fail-safe and uses this position as the base for all of its position calculations. The microprocessor will retain the initialized zero during short power failures of up to 20 seconds. The NF24-MFT US actuator will also return to its position prior to the 20-second-or-less power loss. For power failures greater than 20 seconds the actuator would naturally return to its full fail-safe position prior to the microprocessor losing its memory. When power is applied again, the actuator will re-initialize the zero position. The microprocessor will keep count of these short power failures until 16 occur. At this point, the microprocessor will automatically drive the actuator to its zero position and re-initialize to correct for any possible error accumulation.

### Brushless DC Motor Operation

Belimo's brushless DC motor spins by reversing the poles of stationary electromagnets housed inside rotating permanent magnets. The electromagnetic poles are switched by a microprocessor and a special ASIC (Application Specific Integrated Circuit) developed by Belimo. Unlike the conventional DC motor, there are no brushes to wear or commutators to foul.

### Overload Protection

The Belimo NF24-SR US and NF24-MFT US actuators are protected from overload at all angles of rotation. The on board microprocessor constantly monitors the rotation of the DC drive motor inside the actuator and stops the pulses to the motor when it senses a stall condition. The DC motor remains energized and produces full rated torque to the load. This helps ensure that dampers are fully closed and that edge and blade seals are always properly compressed.

### Motor Position Detection

Belimo brushless DC motors eliminate the need for potentiometers for positioning. Inside the motor are three "Hall Effect" sensors. These sensors detect the spinning rotor and send pulses to the microprocessor which counts the pulses and calculates the position to within 1/3 of a revolution of the motor.

### Control Accuracy and Stability

NF24-SR US actuators have built-in brushless DC motors which provide better accuracy and longer service life.

The NF24-SR US actuators are designed with a unique non-symmetrical deadband. The actuator follows an increasing or decreasing control signal with a 80 mV resolution. If the signal changes in the opposite direction, the actuator will not respond until the control signal changes by 200 mV. This allows these actuators to track even the slightest deviation very accurately, yet allowing the actuator to "wait" for a much larger change in control signal due to control signal instability.

#### NF Actuator responds to a 80 mV signal when not changing direction from stop

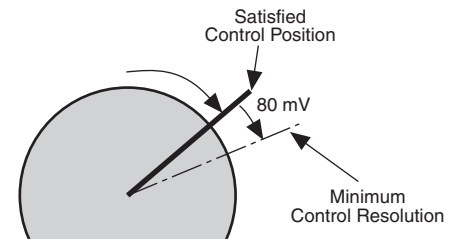

#### NF Actuator responds to a 200 mV signal when reversing direction from stop position.

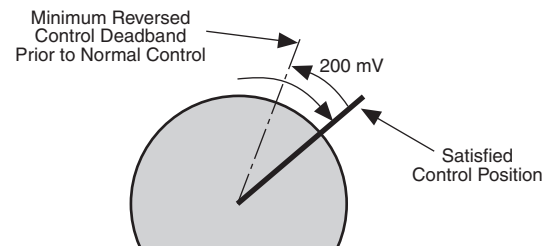

The NF24-MFT US control accuracy and stability can be found in the MFT specifications, page 293.

**WARNING** The wiring technician must be trained and experienced with electronic circuits. Disconnect power supply before attempting any wiring connections or changes. Make all connections in accordance with wiring diagrams and follow all applicable local and national codes. Provide disconnect and overload protection as required. Use copper, twisted pair, conductors only. If using electrical conduit, the attachment to the actuator must be made with flexible conduit.

Always read the controller manufacturer's installation literature carefully before making any connections. Follow all instructions in this literature. If you have any questions, contact the controller manufacturer and/or Belimo.

### Transformers

The NF24 . . actuator requires a 24 VAC class 2 transformer and draws a maximum of 10 VA per actuator. The actuator enclosure cannot be opened in the field, there are no parts or components to be replaced or repaired.

- EMC directive: 89/336/EEC
- Software class A: Mode of operation type 1
- Low voltage directive: 73/23/EEC

**CAUTION:** It is good practice to power electronic or digital controllers from a separate power transformer than that used for actuators or other end devices. The power supply design in our actuators and other end devices use half wave rectification. Some controllers use full wave rectification. When these two different types of power supplies are connected to the same power transformer and the DC commons are connected together, a short circuit is created across one of the diodes in the full wave power supply, damaging the controller. Only use a single power transformer to power the controller and actuator if you know the controller power supply uses half wave rectification.

### Multiple Actuators, One Transformer

Multiple actuators may be powered from one transformer provided the following rules are followed:

1. The TOTAL current draw of the actuators (VA rating) is less than or equal to the rating of the transformer.
2. Polarity on the secondary of the transformer is strictly followed. This means that all No. 1 wires from all actuators are connected to the common leg on the transformer and all No 2 wires from all actuators are connected to the hotleg. Mixing wire No. 1 & 2 on one leg of the transformer will result in erratic operation or failure of the actuator and/or controls.

### Multiple Actuators, Multiple Transformers

Multiple actuators positioned by the same control signal may be powered from multiple transformers provided the following rules are followed:

1. The transformers are properly sized.
2. All No. 1 wires from all actuators are tied together and tied to the negative leg of the control signal. See wiring diagram page 19.

### Wire Length for NF... Actuators

Keep power wire runs below the lengths listed in the table in **Figure E**. If more than one actuator is powered from the same wire run, divide the allowable wire length by the number of actuators to determine the maximum run to any single actuator.

Example for NF24-SR US: 3 actuators, 16 Ga wire  
 $550 \text{ Ft} \div 3 \text{ Actuators} = 183 \text{ Ft}$ . Maximum wire run

#### NF24(-S) US Maximum Wire Length

Wire Size	Max. Feet.	Wire Size	Max. Feet
12 Ga	1100 Ft.	18 Ga	260 Ft.
14 Ga	700 Ft.	20 Ga	140 Ft.
16 Ga	440 Ft.	22 Ga	75 Ft.

#### NF120(-S) US Maximum Wire Length

Wire Size	Max. Feet.	Wire Size	Max. Feet
12 Ga	1250 Ft.	18 Ga	320 Ft.
14 Ga	800 Ft.	20 Ga	160 Ft.
16 Ga	500 Ft.	22 Ga	85 Ft.

#### NF2-SR(-S) US AND NF24-MFT US Maximum Wire Length

Wire Size	Max. Feet.	Wire Size	Max. Feet
12 Ga	1500 Ft.	18 Ga	375 Ft.
14 Ga	925 Ft.	20 Ga	200 Ft.
16 Ga	550 Ft.	22 Ga	100 Ft.

**FIGURE E**

### Wire Type and Wire Installation Tips

For most installations, 18 or 16 Ga. cable works well with the NF24... actuators. Use code-approved wire nuts, terminal strips or solderless connectors where wires are joined. It is good practice to run control wires unspliced from the actuator to the controller. If splices are unavoidable, make sure the splice can be reached for possible maintenance. Tape and/or wire-tie the splice to reduce the possibility of the splice being inadvertently pulled apart.

The NF24... proportional actuators have a digital circuit that is designed to ignore most unwanted input signals (pickup). In some situations the pickup may be severe enough to cause erratic running of the actuator. For example, a large inductive load (high voltage AC wires, motors, etc.) running near the power or control wiring may cause excessive pickup. To solve this problem, make one or more of the following changes:

1. Run the wire in metallic conduit.
2. Re-route the wiring away from the source of pickup.
3. Use shielded wire (Belden 8760 or equal). Ground the shield to an earth ground. Do not connect it to the actuator common.

**NF24-SR US and NF24-MFT US + P-100... Electrical Check-out Procedure**

STEP	Procedure	Expected Response	Gives Expected Response Go To Step...	Does Not Give Expected Response Go To Step...
1.	Control signal is applied to actuator.	Actuator will move to its "Control Signal" position.	Actuator operates properly <b>Step 8.</b>	No response at all <b>Step 2.</b> Operation is reversed <b>Step 3.</b> Does not drive toward "Control Signal Position" <b>Step 4.</b>
2.	Check power wiring. Correct any problems. <b>See Note 1.</b>	Power supply rating should be $\Omega$ the total power requirement of the actuator(s). Minimum voltage of 19.2 VAC or 21.6 VDC.	Power wiring corrected, actuator begins to drive <b>Step 1.</b>	Power wiring corrected, actuator still does not drive <b>Step 4.</b>
3.	Turn reversing switch to the correct position. Make sure the switch is turned all the way left or right.	Actuator will move to its "Control Signal" position.	Actuator operates properly <b>Step 8.</b>	Does not drive toward "Control Signal Position" <b>Step 4.</b>
4.	Make sure the control signal positive (+) is connected to Wire No 3 and control signal negative (-) is connected to wire No. 1. Most control problems are caused by reversing these two wires. Verify that the reversing switch is all the way CCW or CW.	Drives to "Control Signal" position	Actuator operates properly <b>Step 8.</b>	<b>Step 5.</b>
5.	Check input signal with a digital volt meter (DVM). Make sure the input is within the range of the actuator. For NF24-SR US this is 2 to 10 VDC or 4 to 20 mA. <b>NOTE:</b> The input signal must be above the 2 VDC or 4 mA to have the actuator move.	Input voltage or current should be $\pm 1\%$ of what controller's adjustment or programming indicate.	Controller output (actuator input) is correct. Input Polarity Correct <b>Step 6.</b>	Reprogram, adjust repair or replace controller as needed <b>Step 1.</b>
6.	Loosen the nuts on the V-bolt and move the damper by hand from fully closed to fully open..	Damper will go from fully closed to fully open.	Damper moves properly <b>Step 7.</b>	Find cause of damper jam and repair. Move damper back to the fully closed position and tighten the nuts <b>Step 1.</b>
7.	Check damper torque requirement.	Torque requirement is actuator's minimum torque.	Defective Actuator. Replace Actuator - <b>See Note 2.</b>	Recalculate actuator requirement and correct installation.
8.	Actuator works properly. Test controller by following controller manufacturer's instructions.			

- NOTE 1** Check that the transformer(s) are sized properly.
- If a common transformer is used, make sure that polarity is observed on the secondary. This means connect all No. 1 wires to one leg of the transformer and all No. 2 wires to the other leg of the transformer.
  - If multiple transformers are used with one control signal, make sure all No. 1 wires are tied together and tied to control signal negative (-).
  - Controllers and actuators must have separate 24 VAC/VDC power sources.
- NOTE 2** If failure occurs within 5 years from original installation date, notify Belimo and give details of the application.

K20901 - 01/09 - Subject to change. © Belimo Aircontrols (USA), Inc.